

# MARINE CORPS HISTORY

VOLUME 1, NUMBER 2

WINTER 2016



The Tiger of Seibo

The U.S. Marines  
in World War I

# The History Division is moving!

History Division will be moving to the Simmons Marine Corps History Center, part of the Marine Corps University. The new state-of-the-art wing will bring together all of the Marine Corps University schools into one unit. The structure will offer many new features and amenities for the student body, faculty, and staff at Marine Corps Base Quantico.



## The Greene Papers: General Wallace M. Greene Jr. *and the Escalation of the Vietnam War,* January 1964–March 1965

Nicholas J. Schlosser, 2015. Cloth. 418 pp.

*The Greene Papers: General Wallace M. Greene Jr. and the Escalation of the Vietnam War, January 1964–March 1965* contains more than 100 documents from the personal papers of the 23d Commandant of the Marine Corps and is the first edited volume of personal papers to be published by the Marine Corps History Division as a monograph. Produced by a member of the Joint Chiefs of Staff, General Greene's notes provide a firsthand account from one of the main participants in the decision-making process that led to the commitment of a large-scale American expeditionary force in Southeast Asia.

This volume begins in January 1964 and ends just before the landing of the 9th Marine Expeditionary Brigade at Da Nang on 8 March 1965, a pivotal moment that marked the official transition from the United States' advisory mission to a more active combat mission. In doing so, it traces Greene's growing frustration with Secretary of Defense Robert S. McNamara's and President Lyndon B. Johnson's equivocation and uncertainty about Southeast Asia. Along with a series of commemorative pamphlets, this book is part of the Marine Corps History Division's effort to mark the fiftieth anniversary of the Vietnam War.

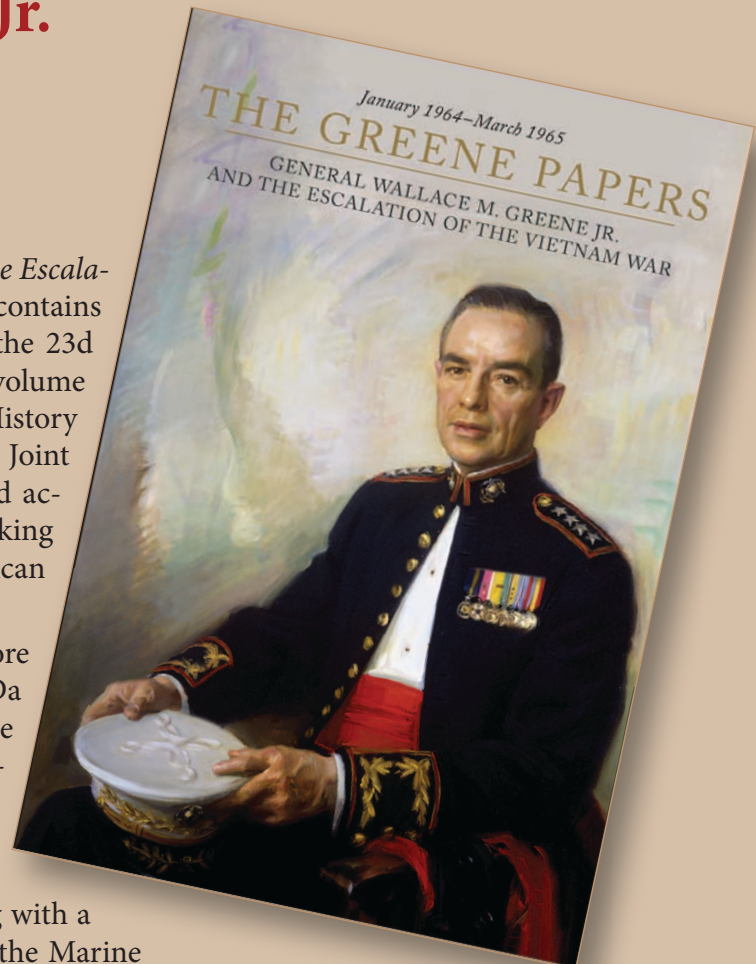



# MARINE CORPS HISTORY

Volume 1, Number 2

Winter 2016

**PRESIDENT**  
of Marine Corps University  
Brigadier General H. G. Pratt  
♦ ♦ ♦

**DIRECTOR**  
of History Division  
Dr. Charles P. Neimeyer

**DEPUTY DIRECTOR**  
Paul J. Weber

**CHIEF HISTORIAN**  
Vacant

**ADMINISTRATIVE ASSISTANT**  
Cassandra Bennett  
♦ ♦ ♦

**HISTORIES BRANCH**  
Vacant (Branch Head); J. Michael Miller;  
Douglas Nash; Paul W. Westermeyer;  
Dr. Brianne Robertson  
♦ ♦ ♦

**HISTORICAL INQUIRIES AND  
RESEARCH BRANCH**  
Annette D. Amerman (Branch Head);  
Beth L. Crumley; Kara R. Newcomer;  
Shelia Phillips  
♦ ♦ ♦

**ORAL HISTORY  
and VIDEO SECTION**  
Dr. Fred Allison and Dr. Tom Baughn  
♦ ♦ ♦

**EDITING AND DESIGN BRANCH**  
Angela J. Anderson (Branch Head); Jen-  
nifer Clampet; Nora Ellis; W. Stephen  
Hill; Dr. Alexandra Kendall; Robert A.  
Kocher; Gregory A. Macheak; Vincent  
J. Martinez; Christianna Sanders; Shawn  
H. Vreeland  
♦ ♦ ♦

**MARINE CORPS  
HISTORY DIVISION**  
3078 Upshur Avenue  
Quantico, Virginia 22134  
Telephone (703) 432-4877  
<http://www.history.usmc.mil>  
[history.division@usmc.mil](mailto:history.division@usmc.mil)  
♦ ♦ ♦

**COMMANDANT OF THE  
MARINE CORPS**  
Department of the Navy  
Headquarters United States  
Marine Corps  
3000 Marine Corps Pentagon  
Room 2B253  
Washington, DC 20530-3000

**OFFICIAL BUSINESS**  
PCN 10600011300  
ISSN 2381-375X

## Cover Art:

Cpl John Henry Pruitt, USMC  
Medal of Honor, Blanc Mont Ridge  
Acrylic on canvas.  
*Gift of the Artist, Col Charles H. Waterhouse,  
USMCR (Ret).*

<b>Director's Foreword</b> <i>Dr. Charles P. Neimeyer</i>	<b>3</b>
<b>The Tiger of Seibo:</b> Charles F. Merkel, George C. Thorpe, and the Dark Side of Marine Corps History <i>Mark R. Folse</i>	<b>4</b>
<b>The U.S. Marines in World War I</b> <b>Part I: The U.S. Marine Corps Reserve</b> Comes to the Fore <i>Colonel Walter G. Ford, USMC (Ret)</i>	<b>19</b>
<b>Development of Medical Doctrine</b> <b>for Amphibious Warfare by the U.S. Navy and</b> <b>Marine Corps, 1929–39</b> Part I <i>Captain Steven L. Oreck, USN (Ret)</i>	<b>43</b>
<b>The Importance of Professionalism:</b> An Analysis of the 1st Marine Division Planning Process for the Amphibious Assault on Inchon <i>Lieutenant Colonel Michael Bonura, USA;</i> <i>Major Michael Padilla, USAF;</i> <i>Major Kwan Seop Lee, Republic of Korea Army</i>	<b>58</b>
<b>National Museum of the Marine Corps:</b> Moving Forward to Tell the Story of Today's Warrior	<b>70</b>
<b>Book Reviews</b>	
<i>Shooting the Pacific War:</i> <i>Marine Corps Combat Photography in WWII</i> Reviewed by Charles Grow	<b>71</b>
<i>War's Nomads: A Mobile Radar Unit in Pursuit</i> <i>of Rommel during the Western Desert Campaign, 1942–3</i> Reviewed by Douglas E. Nash	<b>74</b>
<i>Marine Corps Tank Battles in the Middle East</i> Reviewed by Paul Westermeyer	<b>76</b>
<i>Hirohito's War: The Pacific War, 1941–1945</i> Reviewed by Grant W. Jones	<b>78</b>
<i>D-Day in the Pacific: The Battle of Saipan</i> Reviewed by Mark R. Folse	<b>80</b>
<i>A Call to Arms: Mobilizing America for World War II</i> Reviewed by Bradford A. Wineman	<b>83</b>
<i>WWII: A Chronicle of Soldiering</i> Reviewed by Chris Blaker	<b>85</b>



# DIRECTOR'S FOREWORD



Dr. Charles P. Neimeyer  
Director, History Division  
Marine Corps University

The History Division will be moving into the new Brigadier General Edwin Simmons Historical Center this spring. The first two floors of the center will be dedicated to historical archives, personal papers, and oral/video history. By doing so, we hope to create a “one stop shop” for all historical research related to the Marine Corps. The rest of the division, to include the Historical Inquiries and Research Branch, will be located on the third floor of the center.

This particular edition of *Marine Corps History* is again full of interesting material on the history of our Corps. In keeping with our “telling it like it is” policy, we have included an intriguing article by former History Division intern and PhD candidate Mark Folsie on the controversial campaign conducted by the Marine Corps in Santo Domingo, 1917–18. Colonel Walt Ford, retired editor of *Leatherneck* magazine, contributed a pathbreaking piece on the U.S. Marine Corps Reserve during the First World War.

**Dr. Charles P. Neimeyer:** the director is responsible for the collection, production, publication, and dissemination of Marine Corps history and manages the functioning of a wide variety of Marine Corps historical programs.



Art Collection, National Museum of the Marine Corps  
Belleau Wood by SSgt Kristopher J. Battles, USMCR. Oil on canvas, 2013.

Dr. Steven Oreck wrote a very interesting article on doctrine developed for U.S. Navy medical activities during the interwar years, 1920–39. Finally, Lieutenant Colonel Michael Bonura, USA, wrote a very timely essay on the planning process of the 1st Marine Division on the eve of their historic 15 September 1950 amphibious assault at Inchon, South Korea. This essay is especially germane due to the renewed attention given amphibious warfare doctrine and the Asia-Pacific region. As usual, the magazine contains a number of book reviews on the latest scholarship in military history.

The Marine Corps History Division is looking forward to the publication of the second volume of *Marine Corps History*. As director, I am proud of what we have been able to accomplish this past year and hope to build upon our record of excellence into the future. ♦ 1775 ♦

# The Tiger of Seibo:

## CHARLES F. MERKEL, GEORGE C. THORPE, AND THE DARK SIDE OF MARINE CORPS HISTORY

Mark R. Folse  
History Department  
University of Alabama

In the summer of 1918, the U.S. Marine Corps waged war on insurgents in the eastern provinces of the Dominican Republic. On 24 August, the 52d Company, 1st Battalion, 3d Marine Regiment, entered Hayto Mayor, Dominican Republic, rounded up the residents, and questioned them about bandit activity. Frightened and confused, the residents stood nervously as Captain Charles F. Merkel shouted and fired his pistol in the air to intimidate them. Then, Merkel approached a man standing outside of his home. After a brief conversation, Merkel drew his pistol and shot the man in the head while the crowd watched.<sup>1</sup> Captain Merkel became known as the “Tiger of Seibo,” named after the eastern province of Seibo, which he terrorized.<sup>2</sup> His alleged atrocities of murder and torture are some of the least understood blots on Marine Corps history.

Merkel’s story appears in vignette form in the works of many Marine Corps and Latin American historians but none delve into Captain Merkel’s past, his motivations, his career as an officer, or his impact on the United States’ intervention in the Dominican

Republic.<sup>3</sup> Marine historians often interpret Merkel as a rogue and not a reflection of general Marine misconduct during the occupation. Latin American historians typically use Merkel as an extreme example of the Marine brutality that triggered the 1918 insurgency in the Dominican Republic. Although fair, these interpretations of Merkel’s actions are incomplete and fail to consider the complicity of other Marine Corps officers in the crimes. This article argues that Merkel’s alleged crimes are important and were potentially disastrous for the Marine Corps’ reputation at the time.

The following pages explore Merkel’s possible motivations and the command climate that contributed to his actions. Arguably, his behavior in the Dominican Republic was part of a larger problem affecting Marines, such as misunderstanding the nature and motivations of insurgents, eliciting violence toward indigenous people, losing experienced Marines to the war in Europe, and dealing with a preponderance of officers who wanted to fight in World War I not on the island of Hispaniola.

While Merkel allegedly committed or ordered atrocious acts against the Dominican people, the circumstances in which the infractions occurred

<sup>1</sup> Luis Bautista, *Inquiry into the Occupation and Administration of Haiti and Santo Domingo* (statement, Hearings Before the Select Committee on Haiti and Santo Domingo: Pursuant to S. Res. 112, vol. 1, 67th Cong., 1st and 2d sess., 14 December 1921), 1132.

<sup>2</sup> Lester D. Langley, *The Banana Wars: United States Intervention in the Caribbean, 1898-1934* (Lexington: University Press of Kentucky, 1983), 146.

<sup>3</sup> Robert D. Heinl Jr. and Clyde H. Metcalf focus on Merkel’s combat record, not his criminal acts, and use Merkel’s experience in-country as an example of how hard Marines fought against Dominican insurgents. See Robert Debs Heinl Jr., *Soldiers of the Sea: United States Marine Corps, 1775-1962* (Annapolis, MD: Naval Institute Press, 1962), 248; Clyde H. Metcalf, *A History of the United States Marine Corps* (New York: G. P. Putnam’s Sons, 1939), 359; Lester Langley uses Merkel as an example of an officer who “grew increasingly resentful of occupation duty” as a result of being left out of the Great War. See Langley, *Banana Wars*, 147. Allan R. Millett and other historians blame Merkel for inflaming the insurgency and sending peaceful Dominicans into the bandit ranks; Allan R. Millett, *Semper Fidelis: The History of the United States Marine Corps* (New York: Macmillan Publishing, 1980), 200; Bruce J. Calder, *The Impact of Intervention: The Dominican Republic during the U.S. Occupation of 1916-1924* (Austin: University of Texas Press, 1984), 131; and Alan McPherson, *The Invaded: How Latin Americans and Their Allies Fought and Ended U.S. Occupations* (New York: Oxford University Press, 2014), 93, 97. Stephen M. Fuller and Graham A. Cosmas cite Merkel’s misconduct as a result of “life in isolated outposts, where they [Marines] often exercised wide authority under minimal supervision from superiors, offered temptations of corruption and misuse of power to which a few Marines fell victim.” See Stephen M. Fuller and Graham A. Cosmas, *Marines in the Dominican Republic, 1916-1924* (Washington, DC: U.S. Marine Corps History and Museums Division, 1974). Ivan Musicant argues that Merkel’s actions constituted “one of the most serious atrocities committed” by a Marine against the Dominican people. See Ivan Musicant, *The Banana Wars: A History of United States Military Intervention in Latin America from the Spanish-American War to the Invasion of Panama* (New York: Macmillan, 1990), 281.

also implicate other officers. Most notably, Lieutenant Colonel George C. Thorpe, Merkel's immediate superior and battalion commander, who was also responsible for several Marine officers accused of committing atrocities. Thorpe played a significant part in allowing Merkel's misconduct and deserves to share in the blame for the violent 1918 Dominican insurgency. Merkel believed he was following Thorpe's orders, which involved killing "a whole lot of people."<sup>4</sup> Thorpe denied any culpability and allowed Merkel to be tried for the crimes of murder and torture. However, letters Thorpe penned to his superior officer strongly connect Thorpe to the atrocities. Ultimately, Merkel and his alleged crimes would have been a public relations disaster for the Marine Corps were it not for his suicide. His death precluded a court-martial, keeping the story out of U.S. newspapers.

An often overlooked element, however, is the impact of the Great War on the attitudes and behaviors of Marines serving in both Haiti and the Dominican Republic. Marines landed on Haitian shores in 1915 to quell a civil war, which began with the assassination of the Haitian president and a takeover of the government by armed rebels.<sup>5</sup> President Woodrow Wilson deemed the actions a threat to American lives and interests on Hispaniola and ordered Rear Admiral William B. Caperton on the USS *Washington* (ACR 11) to land Marines near Port-au-Prince, Haiti. A Marine brigade landed in Santo Domingo, Dominican Republic, in 1916 when the American-backed Juan Isidro Jimenes lost control of the government. Rival political factions rebelled against Jimenes because of his pro-American policies.<sup>6</sup> In both countries, Marines fought insurgents, formed constabularies, and established as much military and political control over the fractious region as possible. More than a year before the United States entered World War I, the Marines entered a smaller war in Hispaniola, a war historians characterize as a counterinsurgency.

Once the U.S. Congress declared war on Germany in April 1917, the situation in Hispaniola changed because many Marines wanted to fight the Great War but not all could. President Wilson and Congress authorized the Marine Corps to expand to an unprecedented size, to send men to France, and to maintain expeditions in Hispaniola and elsewhere. Thus many Marines remained stationed in Hispaniola, and newly assembled units often headed to the Caribbean instead of across the Atlantic.

Marine field grade officers, including Smedley D. Butler, focused on the war in Europe and awaited orders to France. Butler was an experienced officer who had served in the Spanish-American War, the Philippines, China, and Mexico. Butler believed that his service in Haiti as the commander of Marine and Haitian *gendarmarie* forces was noble and important until the United States entered the Great War. "This work here would be more interesting and worthwhile," he wrote his parents in October 1917, "but under the circumstances it is unbearable . . . This thing of being left out of the show is really more than I can stand, and I tell you both very truthfully that I shall never show my face in West Chester again if I am not allowed to go to France."<sup>7</sup>

In letters to family, Butler implied profound depression regarding his role in the war and questioned his long service with the Marine Corps. "Had I remained in civil life," he lamented, "I could have gone to France at least as a lieutenant, and saved my face, while now . . . I must sit here under a foreign flag, while my country goes to war."<sup>8</sup> He claimed to be willing to do anything to go to France, including reduction in rank: "It isn't as if I asked to be sent as a general or even a colonel or even a lieutenant colonel. I would welcome any position from private on down."<sup>9</sup> Even the thought of his extended family serving in France caused mental anguish:

Bunny has 14 near male relations in the [U.S.] Army, from privates up to lieutenants and all my able bodied kinfolk have gone—all males on

<sup>4</sup> Charles F. Merkel letter to Russell W. Duck, 2 October 1918, Charles Merkel personnel file, NPRC, St. Louis, MO.

<sup>5</sup> Steeve Coupeau, *The History of Haiti* (Westport, CT: Greenwood Press, 2008), 68.

<sup>6</sup> Frank Moya Pons, *The Dominican Republic: A National History* (Princeton, NJ: Markus Wiener Publishers, 1998), 314-15; and Ian Bell, *The Dominican Republic* (Boulder, CO: Westview Press, 1980), 62-64.

<sup>7</sup> Butler letter to his parents, 6 October 1917, *Smedley D. Butler Papers*, Marine Corps History Division Archives Branch, Gray Research Center (GRC), Quantico, VA, hereafter Butler letter to his parents.

<sup>8</sup> *Ibid.*

<sup>9</sup> *Ibid.* Emphasis in original.

both sides but me the one professional soldier . . . they can readily see why I could never associate with anyone after the war. Some day my grandchildren will be subjected to the remark “where was your grandfather during the big war?” And they will have to lurch their heads in shame and either lie or say “he was a policeman in the service of a foreign and black Republic.”<sup>10</sup>

Due partly to his father’s political connections, Butler finally shipped out to France in 1918, but many officers who also requested transfers to France stayed put in Hispaniola.<sup>11</sup>

Marine officers in the Dominican Republic expressed similar sentiments as Butler. Lieutenant Colonel Thorpe wanted to go to France and believed he had a chance if he could prove himself competent: “If I do a good job of clearing these two provinces of insurgents,” he reasoned, “maybe I go to a more active field of endeavor too . . . I’d be a good German killer.”<sup>12</sup> Unable to fight the Germans in France, many Marines made do with fighting Germans on the island instead.

Once the United States entered the Great War, Marines equated the fighting in Hispaniola with the war against Germany. Since the turn of the century, Americans considered Germany to be an economic and strategic rival in the Caribbean.<sup>13</sup> For the first two decades of the twentieth century, German officials and businessmen traveled throughout the Caribbean to conduct commercial ventures.<sup>14</sup> By the time the Marines arrived, hundreds of Germans had established themselves in the social and economic milieu of Haiti and the Dominican Republic.<sup>15</sup>

American policy makers believed that Germans intended to establish a colony at the doorstep of the United States—a blatant violation of the Monroe Doctrine and threat to the security of the Panama Canal.<sup>16</sup> Therefore, when Marines landed in Haiti in 1915 and the Dominican Republic in 1916, their attitudes toward resident Germans hardened after the United States entered the war. Marines in Haiti for example took a secret census of all Germans in-country and later confiscated the property of and imprisoned those suspected of subversive activities.<sup>17</sup>

The driving force behind Marine hostility toward Germans was the belief that they were directing insurgent activity—thus connecting the small war in Hispaniola to the bigger war in France. In the Dominican Republic, Lieutenant Colonel Thorpe claimed that a recent spike in insurgent activity “shows the handiwork of the German as certain as can be, there is no doubt in my mind that a German is commanding the enemy’s campaign.”<sup>18</sup> Another Marine officer in Santo Domingo claimed that “the pro-German element is at work stirring up the minds of the people . . . I believe that if the Germans had some big win in Europe we would have here a general insurrection.”<sup>19</sup> According to contemporary reports, insurgent activity increased in the spring and summer of 1918. The cause for the spike was controversial, but Marines believed the Germans masterminded it.<sup>20</sup> Joseph Henry Pendleton wrote that Marines in the summer of 1918 “were campaigning against Germany, German influence, German money, and German-inspired revolt.”<sup>21</sup>

These beliefs led to a blatant misunderstanding

<sup>10</sup> Ibid.

<sup>11</sup> Hans Schmidt, *Maverick Marine: General Smedley D. Butler and the Contradictions of American Military History* (Lexington: University Press of Kentucky, 1987), 1.

<sup>12</sup> George C. Thorpe letter to Joseph Pendleton, 21 August 1918, *Joseph Pendleton Papers*, Marine Corps History Division Archives Branch, GRC, Quantico, VA.

<sup>13</sup> Calder, *The Impact of Intervention*, 22; and Hans Schmidt, *The United States Occupation of Haiti, 1915-1934* (New Brunswick, NJ: Rutgers University Press, 1971), 34-35.

<sup>14</sup> Mary A. Renda, *Taking Haiti: Military Occupation and the Culture of U.S. Imperialism, 1915-1940* (Chapel Hill, NC: University of North Carolina Press, 2001), 51; Schmidt, *United States Occupation of Haiti*, 91; and Calder, *The Impact of Intervention*, 68-69.

<sup>15</sup> Schmidt places the number of Germans in Haiti around the time of intervention at 210. See Schmidt, *United States Occupation of Haiti*, 91.

<sup>16</sup> American foreign policy from 1823 focused on three ideas: separate spheres of influence for the Americas and Europe, no further colonization in the Americas, and no intervention in Western matters.

<sup>17</sup> Schmidt, *United States Occupation of Haiti*, 95; and “Reports Relating to Operations in Haiti and Santo Domingo, 1915-21,” *Records of U.S. Marines in Haiti*, RG 127, box 2, U.S. National Archives and Records Administration, Washington, DC.

<sup>18</sup> Col George C. Thorpe to Joseph Pendleton from San Pedro de Macoris, Dominican Republic, 18 August 1918, *Pendleton Papers*, Marine Corps History Division Archives Branch, GRC, Quantico, VA.

<sup>19</sup> L. Nogart to Joseph Pendleton, 16 April 1918, *Pendleton Papers*, Marine Corps History Division Archives Branch, GRC, Quantico, VA.

<sup>20</sup> Col George C. Thorpe to Joseph Pendleton, 18 August, 1918.

<sup>21</sup> BGen Joseph Pendleton to the secretary of the U.S. Navy, 24 July 1919, *Pendleton Papers*, Marine Corps History Division Archives Branch, GRC, Quantico, VA.



of the situations in both countries. Historian Hans Schmidt argues that in Haiti, “All the investigations of rumors, surveillance of German firms, censoring of letters, and other counterespionage work failed to turn up much concrete evidence of German intrigue.”<sup>22</sup> Much of the resistance Marines experienced in Haiti stemmed from the notorious corvee work system—employed Haitians who could not pay the road tax provided labor instead. The system had been used before in Haiti, and Marines assumed that it would work. However, many Haitians saw the work system as slave labor and resisted.<sup>23</sup>

Bruce J. Calder argues that the Dominican Republic’s spike in insurgent activity in 1918 stemmed from a misunderstanding of, or disrespect for, local politics in the eastern provinces. *Caudillos*—local men who had charisma, military skills, economic resources, and important family ties—controlled much of eastern Dominican Republic and had for generations. The caudillo system was embedded deeply into Dominican political culture, but Marines “either failed to understand it or completely misjudged the strength of the caudillo system,” argues Calder.<sup>24</sup> World War I also seriously hindered the country’s export trade, which negatively affected many Dominicans’ economic prospects.<sup>25</sup> So what the Marines, especially Thorpe, saw as a German-inspired revolt, led by bandit leaders, was actually a grassroots resistance with Dominicans fighting against foreign intrusion and economic exploitation and being led by trusted local political and military leaders. Thorpe’s and Merkel’s actions occurred within this broader context.

Marines framed the wars in Hispaniola within the context of the larger war against Germany, in part, to demonstrate the need for experienced units to remain in-country. Once the war began, the Marine Corps pulled most its experienced companies out of Hispaniola, which irritated brigade commanders. In

April 1917, a brigade commander in Haiti reported “the reduction of the number of Marines in Haiti by two companies is, in my opinion, a serious mistake . . . It is necessary in my mind that we increase our influence in this island and not weaken it . . . to withdraw troops just at this time . . . cannot but have a very unfortunate effect.”<sup>26</sup> For the Marines, undermanned brigades equated to longer and more dangerous patrols, shortages in manpower for security posts, and sagging morale.<sup>27</sup>

Therefore, when Captain Merkel arrived in the Dominican Republic in the spring of 1918, he encountered a command climate that misunderstood insurgent motivations and suffered from an overwhelming desire to play a bigger part in the Great War. In the Dominican Republic, a revival of bandit activity in 1918 challenged the 2d Marine Brigade, which had been stripped of much needed manpower, materiel, and leadership.<sup>28</sup> “To face this situation what do we have?” wrote one Marine officer. “Men of experience . . . have gone, other men . . . are on the limit of their two-year period and probably on the eve of their departure.”<sup>29</sup> Establishing and maintaining control over the countryside became more difficult, and as will be explored below, Merkel joined a command that often used harsh tactics to maintain order.

Lieutenant Colonel Thorpe, Merkel’s original recruiting officer, who now served as Merkel’s battalion commander in the Dominican Republic, believed strongly that Germans funded and led the local insurgency. Thorpe wrote many of the documents that describe Marine efforts to suppress the insurgency of late spring and summer of 1918. Therefore, much of what is known about Merkel’s actions and the Marines’ attempts to restore peace by waging war in Seibo Province originated from Thorpe.

Marine officers under Thorpe’s command began killing indigenous people in early 1918 in retaliation

<sup>22</sup> Schmidt, *United States Occupation of Haiti*, 92.

<sup>23</sup> Capt John H. Craig, *Development of the Republic of Haiti*, general correspondence, Operations and Training Division, intelligence section, 1915–1934, H-134, Haiti box 14, entry 38, National Archives, Washington, DC.

<sup>24</sup> Bruce J. Calder, “Caudillos and Gavilleros versus the United States Marines: Guerilla Insurgency during the Dominican Intervention, 1916–1924,” *Hispanic American Historical Review* 58, no. 4 (November 1978): 656.

<sup>25</sup> Millett, *Semper Fidelis*, 196.

<sup>26</sup> BGen George Barnett, *Report on Affairs in the Republic of Haiti, June 1915 to June 30, 1920* (Washington, DC: Headquarters Marine Corps, 1920), 50.

<sup>27</sup> Millett, *Semper Fidelis*, 196.

<sup>28</sup> *Ibid.*, 196.

<sup>29</sup> L. Nogart to Joseph Pendleton.



Leatherneck, May 1937, 57

Only known photograph of Charles Merkel (front row, second from left) seated among a group of officers and NCO's of the Marine detachment onboard the USS *New York*, February 1916.

for the murder of Captain William R. Knox, who served temporarily as a captain in the *Guardia Nacional* (the Dominican Republic's national guard). Merkel arrived in-country in March 1918. Captains Thad T. Taylor, Harry Seipel, and Knox led an expedition that captured a prominent bandit and caudillo named Ramon Hatera and a dozen of his associates. While being transported to San Pedro de Macorís, Hatera and some of his men escaped. Hatera allegedly wanted revenge for his capture, and in January 1918, Dominican insurgents murdered Captain Knox. Knox was well liked, well respected, and known as "a champion of civic improvement in his district."<sup>30</sup> According to Thorpe, First Lieutenant Hatton, who replaced Knox, in retaliation allegedly executed 11 men suspected of being involved in Knox's murder.<sup>31</sup> After Knox's death, Taylor believed "that all circumstances called for a campaign of frightfulness," so he "arrested indiscriminately upon suspicion and then

people rotted in jail pending investigation or search for evidence."<sup>32</sup> "Just as Captain Knox used discretion and accomplished a great deal of governmental progress in Seibo, Captain Taylor used no discretion and created unrest and dissatisfaction and anarchy," Thorpe wrote in a 1918 confidential report.<sup>33</sup>

The murder of Captain Knox served as a turning point for Marines in the eastern provinces of Seibo and San Pedro de Macorís. His death led to violence against the indigenous people, which in turn sent Dominicans into the ranks of insurgent groups. Since they believed "the permitted escape of Hatera was really the cause for all the recent trouble in Seibo as well as for the loss of that valuable officer, Knox," Marines attempted to guarantee that captured bandits remained in custody.<sup>34</sup> Unfortunately, Marines including Captain Taylor used the fear of attempted escapes to abuse and even execute suspected bandits. These acts terrorized local Dominicans. Thorpe

<sup>30</sup> Millett, *Semper Fidelis*, 200.

<sup>31</sup> LtCol George C Thorpe, "Confidential Report upon Conditions in Seibo and Macorís Provinces," hereafter "Confidential Report," 30 May 1918, *Joseph Pendleton Papers*, Marine Corps History Division Archives Branch, GRC, Quantico, VA. 1stLt Hatton's full name is mystery, at the moment. According to 1st Battalion, 3d Regiment, muster rolls for 1918, copies of which are held at Marine Corps History Division, Quantico VA, Hatton does not exist. "Hatton" might be a misspelling of "Patten," however. If that is the case, then this Marine was probably Lt Gerald R. Patten of the 115th Company.

<sup>32</sup> Thorpe, "Confidential Report."

<sup>33</sup> *Ibid.*

<sup>34</sup> *Ibid.*

noted that Dominicans were “deadly fearful of being arrested because of the uncertainty of getting a hearing,” and as a result “a number of unsteady ones joined the *Cabilleros*.”<sup>35</sup>

Thorpe also believed that Taylor’s actions corrupted the methods of many officers around him. “Captain Taylor had a very bad effect upon other officers, who acquired the idea that lawlessness and utter disregard of civilians’ rights was proper and admirable conduct for military forces,” Thorpe wrote.<sup>36</sup> On 14 April 1918, Taylor and a group of Marines captured a Syrian national living in Hayto Mayor. Known locally as Agapito José, the Syrian was suspected of being involved in the Knox murder.<sup>37</sup> After Marines shot and killed Agapito in the street, Taylor then allegedly “took a dagger and driving it in his [Agapito’s] throat slashed down to the abdomen.”<sup>38</sup> Taylor’s accomplices were Captain Russell W. Duck and newly arrived Captain Charles F. Merkel. All the officers present at the incident claimed that Agapito was shot and killed as he tried to escape.<sup>39</sup> By April 1918, three of Thorpe’s company commanders allegedly participated in controversial killings, none of which were seriously investigated.

Thorpe cited Merkel’s German ancestry in an evaluation of the Agapito incident. “Captain Merkel, during operations around Hayto Mayor, conducted himself as a German might be expected without regard for feelings of natives, with no attempt at courtesy, and with a good deal of arbitrariness,” Thorpe wrote.<sup>40</sup> But Thorpe also argued that Merkel “had a great amount of energy and ability to endure hardships and is thorough; he is an excellent officer with the exceptions noted.”<sup>41</sup>

By this time, Merkel had acquired a notorious, but not violent, reputation among his superior officers

for being forceful and harsh, which came up often in his fitness reports. Major H. G. Snyder’s report claimed “Merkel is a capable officer; an indefatigable worker; but he is super sensitive; and at times bull headed and peevish, requiring tactful handling.”<sup>42</sup> In a fitness report dated March 1918, Merkel’s general temperament was described as “calm and even tempered,” although Merkel was also “very active . . . forceful . . . and thorough.”<sup>43</sup> Despite these cautionary words, the reviews are bereft of any real indication that Merkel would one day turn malicious or murderous. Under Thorpe’s command, however, Merkel transformed his sensitive and forceful nature into violent and cruel conduct.

The subsequent capture and torture of Pedro Hernandez Rivera of Hayto Mayor shortly after Agapito’s death illuminated what Thorpe and others described as “thorough” and “forceful.” Merkel reportedly tied Rivera to a horse by his neck and hands. Marines trotted the horse for several kilometers to reach a secluded area. Merkel then reportedly tortured Rivera, who testified that “I was placed on my back, with my face to the sun, and was kept there for about two hours while water was poured through a funnel at intervals, and when I refused to open my mouth they forced it open with a stick.”<sup>44</sup> The simulated drowning reportedly continued for two minutes at a time or until Rivera lost consciousness. Merkel repeated the process for four or five days before realizing he had captured the wrong man. These actions did not endear the Marines to the Dominicans.

In June 1918, Captain Merkel enacted his operational methodology on the people of Pedro Santana when they failed to answer his questions about the whereabouts of local bandits. He ordered 25 men, women, and children to be tied together, “threatening

<sup>35</sup> Ibid.; Millett, *Semper Fidelis*, 200; *cabilleros* is Thorpe’s spelling for the Spanish word *gavilleros*, which in the Dominican Republic meant “rural bandit.” According to Bruce Calder, some Dominican insurgents resented being called *gavilleros* and preferred the title revolutionary; Calder, “Caudillos and Gavilleros,” 660.

<sup>36</sup> Thorpe, “Confidential Report.”

<sup>37</sup> Major General Commandant letter to the judge advocate general of the Navy, 9 November 1925, RG 80 general correspondence, National Archives, Washington, DC, hereafter Major General Commandant letter to the judge advocate general. Agapito was also known as Azepto José, who was a store owner in the Dominican Republic. His real name was Habib Koziah.

<sup>38</sup> *Hearings into the Occupation and Administration of Haiti and Santo Domingo, Before the Select Committee on Haiti and Santo Domingo*, 67th Cong. 1136 (14 December 1921) (statement of Jesus M. Vasquez).

<sup>39</sup> Major General Commandant letter to the judge advocate general.

<sup>40</sup> Thorpe, “Confidential Report.”

<sup>41</sup> Ibid.

<sup>42</sup> Report on the fitness of officers of the U.S. Marine Corps, Charles F. Merkel, 10 November 1917 (Merkel personnel file, NPRC, St. Louis, MO) 4.

<sup>43</sup> Report on the fitness of officers of the U.S. Marine Corps, March 1918 (Merkel personnel file, NPRC), 2.

<sup>44</sup> *Hearings into the Occupation and Administration of Haiti and Santo Domingo, Before the Select Committee on Haiti and Santo Domingo*, 67th Cong. 1122 (13 December 1921) (statement of Pedro Hernandez Rivera).

## Captain Charles F. Merkel: Early Marine Career

The life Merkel had before serving in the Dominican Republic is worth recounting because his nationality, connection to Thorpe, and behavior all became relevant to the alleged atrocities. Merkel was born on 26 June 1889 in Mannheim, Germany. At an unknown date, he immigrated to the United States. According to records, he enlisted in the U.S. Marine Corps on 15 September 1908 at age 19. Interestingly, Major George C. Thorpe, then serving as a recruiting officer in Newark, New Jersey, enlisted Merkel.<sup>1</sup> Thorpe was likely one of the first Marines that Merkel ever knew.

Merkel served as a guard at the Portsmouth Naval Prison in Maine, and he requested transfers to the Philippines and Panama in 1909 but was denied due to a lack of vacancies at both places. Merkel's duty stations included the Navy yards in New York, Portsmouth, and Norfolk, Virginia, and the Marine Barracks in Annapolis, Maryland, and Charleston, South Carolina. In 1912, as a sergeant and temporary gunnery sergeant, Merkel became warden of the naval prison onboard the USS *Hancock* (AP 3). He deployed to Veracruz, Mexico, in 1914 and later served with the Marine detachment on the USS *New York* (BB 34).<sup>2</sup> Except for a few instances of insubordination during his first year in the Marine Corps, superior officers gave Merkel excellent proficiency and conduct marks on his fitness reports throughout his first two enlistments.<sup>3</sup>

Merkel's rapid promotions indicate a successful and competent Marine. By 1916, Merkel attained the rank of first sergeant. In July 1917, he received a commission as a temporary second lieutenant followed quickly by first lieutenant. By 17 December, he was promoted to captain.<sup>4</sup> After serving several months at Marine Corps Recruit Depot Parris Island, South Carolina, Merkel arrived in the Dominican Republic in March 1918 and assumed command of the 52d Company, 1st Battalion, 3d Marines, operating out of San Pedro de Macorís.<sup>5</sup> Merkel's Marine Corps records prior to the Dominican Republic did not indicate violent behavior.



Marine's Magazine, September 1917, 5  
LtCol George C. Thorpe with Vicentico Evangelista, a captured insurgent.

Merkel's rapid promotions indicate a successful and competent Marine. By 1916, Merkel attained the rank of first sergeant. In July 1917, he received a commission as a temporary second lieutenant followed quickly by first lieutenant. By 17 December, he was promoted to captain.<sup>4</sup> After serving several months at Marine Corps Recruit Depot Parris Island, South Carolina, Merkel arrived in the Dominican Republic in March 1918 and assumed command of the 52d Company, 1st Battalion, 3d Marines, operating out of San Pedro de Macorís.<sup>5</sup> Merkel's Marine Corps records prior to the Dominican Republic did not indicate violent behavior.

<sup>1</sup> Charles F. Merkel personnel file, National Personnel Records Center (NPRC), St. Louis, MO, hereafter Merkel personnel file.

<sup>2</sup> Application for examination as Marine gunner, 8 September 1916, Merkel personnel file, NPRC, St. Louis, MO.

<sup>3</sup> Ibid.

<sup>4</sup> Ibid.

<sup>5</sup> Ibid.

them with death if they did not state where they [the bandits] were to be found."<sup>45</sup> Merkel then forced them to march blindfolded toward San Lorenzo, where he stopped the column just outside of town and spent four days interrogating and torturing the prisoners.

Those awaiting interrogation were tied to a tree.<sup>46</sup> He eventually released the prisoners but then captured another group of people and repeated the process.<sup>47</sup>

By the summer of 1918, the 2d Brigade, 3d Marine Regiment, faced an intense counterinsurgency cam-

<sup>45</sup> Ibid., 1142.

<sup>46</sup> Ibid.

<sup>47</sup> Ibid.

paign, caused by local reactions to either cultural misunderstandings or Marine misconduct.<sup>48</sup> Since the Marines' arrival two years prior, counterinsurgency in the Dominican Republic had been a significant challenge, and by most accounts, the experience was very frustrating for the American forces present. One Marine lieutenant claimed that on most patrols when enemy contact was made, the bandits would fire a few shots then flee.<sup>49</sup> Often the local population would not identify the insurgents. In June 1917, a Marine officer complained that the Dominican people "hate us so that they will not give us information of any value . . . in practically all of Seibo Province the people have a deep dislike of us."<sup>50</sup> The insurgency strained the Marines' patience and endurance. Brigade Commander, Brigadier General Pendleton, dispatched companies into the interior of the country to track and eliminate roving bands of Dominicans reportedly looking to commit raids, theft, and murder. "Detachments are often out several days," Thorpe reported. "That's the only way to catch the enemy—to get on the trail and stay on it."<sup>51</sup> Marine companies patrolled for days at a time in the Dominican hills and jungles. "Those who have really been doing good work are hollow-cheeked and thin as crows," claimed Thorpe.<sup>52</sup>

Merkel and his Marines endured some of the worst of the insurgency. On 15 July, bandits ambushed his patrol in the hills outside of San Pedro de Macoris. The opening shot of the ambush passed Merkel's face and knocked off the hat of another Marine.<sup>53</sup> In the fight that ensued, Merkel's company suffered three casualties but claimed to have killed eight of the enemy and wounded two. The bandits fled into the

countryside, however, leaving Merkel and his men empty handed. This engagement was covered in the U.S. newspapers and in Clyde Metcalf's *A History of the United States Marine Corps*.<sup>54</sup> The newspapers and Metcalf used Merkel's skirmish as an example of the tough job that Marines were doing in the Dominican Republic. Metcalf, who published his book in 1939, mentions nothing further about Merkel.

Another engagement with insurgents undoubtedly added to Merkel's frustration. While leading a patrol of about 30 Marines and guardia troops, Merkel stumbled across a group of suspected bandits crossing a flooded area. Merkel ordered his men to open fire. Thorpe reported that "the whole Marine detachment had that bunch under fire in the open at about 300 yards or less for a long time and didn't hit one of them."<sup>55</sup> Merkel and his Marines could do nothing but continue to track the elusive enemy through tough terrain and unfriendly indigenous communities during the hot Dominican summer. To persevere under these conditions required patience and determination. But the situation in Seibo Province also required restraint, something that Merkel—already known among his peers for being forceful and peevish—used sparingly.

A crucial turning point in Merkel's behavior came in August 1918 when Thorpe instituted a campaign known by the locals as *reconcentraciones*. The campaign gathered Dominicans from the countryside into camps located in the larger urban centers.<sup>56</sup> By placing populations of Dominicans under surveillance and control, the plan was to allow the Marines to separate the good Dominicans from the bad.<sup>57</sup> During this campaign, Merkel committed his most

<sup>48</sup> Millett, *Semper Fidelis*, 200; Calder, *The Impact of Intervention*, 131; and McPherson, *The Invaded*, 93, 97.

<sup>49</sup> LtGen Edward A. Craig, intvw by Maj L. E. Tatem, 1968, transcript, Marine Corps Oral History Collection, Marine Corps History Division Archives Branch, Quantico, VA.

<sup>50</sup> Henry C. Davis to regimental commander, "Report of Field Operations," 34th Provisional Regt, 1 June 1917, Campaign Files, Dominican Republic, Marine Corps History Division Archives Branch, Quantico, VA. 1.

<sup>51</sup> George C. Thorpe to Joseph Pendleton, 19 September 1918.

<sup>52</sup> Ibid.

<sup>53</sup> Capt Charles F. Merkel to battalion commander, "Operations, field, from 15 July 1918 to 16 August 1918," geographic files, Dominican Republic 1917–1919, Marine Corps History Division Archives Branch, Quantico, VA.

<sup>54</sup> "U.S. Marines Kill Domingo Bandits," *Washington Post*, 30 July 1918; and Clyde H. Metcalf, *A History of the United States Marine Corps* (New York: G. P. Putnam, 1939), 359.

<sup>55</sup> Thorpe to Pendleton, 19 September 1918.

<sup>56</sup> Campaign Order No. 1, Headquarters Battalion, 3d Provisional Regt, San Pedro de Macoris, DR, 20 August 1918, *Pendleton Papers*, Marine Corps History Division Archives Branch, GRC, Quantico, VA, hereafter Campaign Order No. 1.

<sup>57</sup> Langley, *Banana Wars*, 146; and Calder, *The Impact of Intervention*, 149. Dr. Alejandro Coradin of Hayto Mayor witnessed the concentration efforts firsthand, however, and noted that the "concentration of the wretched inhabitants of the commune of Hayto Mayor who had been locked up like pigs in stockades under the pretext of investigating whether or not they were bad persons, a procedure which we can call puerile." Dr. Alejandro Coradin, *Inquiry into the Occupation and Administration of Haiti and Santo Domingo* (statement, Hearings Before the Select Committee on Haiti and Santo Domingo: Pursuant to S. Res. 112, vol. 1, 67th Cong., 1st and 2d sess., 13 December 1921), 1119.

notorious crimes. Prior to August, Merkel had been abusive toward indigenous people but had not committed murder. That changed when the intensive campaign began.

Merkel's actions outside of the concentrated areas indicate that he treated every Dominican like a bandit. Technically, this behavior followed the 20 August campaign orders signed by Thorpe that stated explicitly

All good Dominicans are then supposed to be in the cities, leaving the country clear for operations . . . *Armed Dominicans that flee will be shot* [emphasis author's]. Other persons suspected of being enemies or aiding the enemy will be arrested and sent to nearest base under guard. Hunt out the bandits in all the hills and barrios in the designated zones.<sup>58</sup>

Merkel also received classified orders titled "Instructions for Troops in Fight Against Bandits" that mandated that "a court-martial must be ordered for every case of prisoner escape if [a] soldier is properly present."<sup>59</sup> The latter order likely stemmed from Captain Knox's murder the previous January, where the alleged perpetrators were insurgents who had escaped from Marine custody. Therefore, Merkel not only had a mandate to use deadly force on fleeing prisoners, but he could potentially face a court-martial if they escaped. Dominicans died under this pretext, the exact number is unknown.

According to eyewitness testimony gathered before the U.S. Senate Committee on Haiti and Santo Domingo in 1920–21, Merkel terrorized the countryside around Hayto Mayor and San Pedro de Macoris in September 1918. Four years after the alleged atrocities, witnesses gave their accounts of events, which often included conflicting dates.<sup>60</sup> But all who testified agreed that Merkel had murdered Domini-

cans after the beginning of Thorpe's campaign in late August and early September.

Merkel led a detachment of Marines and guardia from San Pedro de Macoris toward Dos Rios. During that trek, according to Emilio Suarez—Merkel's guide and interpreter—Merkel ordered the towns of Matapolacio and El Salto burned. Merkel's men then captured a wounded man named Armado Mejia outside of El Salto near a riverbank. Believing that Mejia was a bandit, Merkel told Mejia that he "ought to state where his companions were."<sup>61</sup> Mejia replied that he did not know. Merkel then beat him, cut off one of his ears, and carved crosses into his chest.<sup>62</sup> Marines then tightly secured Mejia, who was bloodied, bruised, and in excruciating pain, to a horse and took him to Dos Rios.

What happened next is known as the "pickax incident" and represents one of Merkel's most malevolent acts. Upon arriving in Dos Rios, Merkel ordered the capture of two men suspected of banditry, one of them suffered from a virulent skin disease known as yaws.<sup>63</sup> Merkel suspected the men were bandits because they defied Thorpe's orders to stay in the town. Both men claimed "they were suffering with that bad disease, and [were afraid] they might infect people of the city," and so they stayed out of town.<sup>64</sup> That evening, Merkel ordered Suarez and a few Marines to use their knives to kill the diseased man. Suarez said he refused "because the man had not offended us, and he (Merkel) had many rifles and machine guns and could use them on him."<sup>65</sup> Merkel then tasked a sergeant with shooting the man, and the sergeant did. "He [the man] fell on the ground alive," Suarez testified. "Then, the enlisted man drove a pickax through his head from one side to the other."<sup>66</sup> Merkel ordered the body to be buried, but Suarez and the sergeant feared that they would contract the disease if they touched the body. So the two used

<sup>58</sup> Campaign Order No. 1.

<sup>59</sup> George C. Thorpe, "Instructions for Troops in Fight against Bandits," 20 August 1918, *Pendleton Papers*, Marine Corps History Division Archives Branch, GRC, Quantico, VA.

<sup>60</sup> Emilio Suarez, *Inquiry into the Occupation and Administration of Haiti and Santo Domingo* (statement, Hearings Before the Select Committee on Haiti and Santo Domingo: Pursuant to S. Res. 112, vol. 1, 67th Cong., 1st and 2d sess., December 14, 1921), hereafter Emilio Suarez statement, 1144.

<sup>61</sup> *Ibid.*, 1142.

<sup>62</sup> *Ibid.*

<sup>63</sup> Yaws is a chronic bacterial infection that typically affects skin, bones, and joints.

<sup>64</sup> Emilio Suarez statement, 1144.

<sup>65</sup> *Ibid.*

<sup>66</sup> *Ibid.*

a rope to drag the corpse out of town and disposed of it in the hills. Then, irritated that Suarez had disobeyed an order, Merkel allegedly threatened to kill Suarez on the spot.<sup>67</sup>

A short time later, Marines brought three Dominicans accused of theft before Merkel, who decided to make an example of them “in order that no more robberies might be committed in Dos Rios.”<sup>68</sup> Merkel brought all five prisoners—Mejia who had been tortured, the companion of the man with yaws, and the three suspected thieves—back to Hayto Mayor with the Marine company. Just off a road in a field near Mata Lambre, Merkel reportedly executed four of the prisoners under the guise of attempted escape.<sup>69</sup> “Then he ordered Armado Mejia, whose ear had been cut off, to tell him [Merkel] where his companions were, saying that if he [Mejia] did not tell him, he [Merkel] was going to shoot him,” Suarez claimed.<sup>70</sup> Mejia reportedly could not state where his companions were. According to Suarez, Merkel then set Mejia’s pants on fire attempting to persuade Mejia to talk, but he reportedly had nothing to tell.

Merkel then ordered his Marines to throw oranges at Mejia and beat him. Suarez testified that Mejia “asked them [the Marines] to kill him and not torture him so much,” to which Merkel reportedly replied coldly “that he [Mejia] was a bandit and should die little by little; that bandits should neither eat, drink, nor sleep . . . and that he would not give him anything else to eat until he died of hunger and thirst.”<sup>71</sup> But, after about a week of torture, Mejia’s ordeal ended once Merkel and his detachment arrived in Hayto Mayor. Mejia’s savior was Lieutenant Colonel Thorpe. Upon seeing Mejia’s condition, Thorpe took Mejia out of Merkel’s custody and assigned a physician to see him. Merkel likely met with Thorpe at this time, but no records document such a meeting or, if a meeting occurred, what was said. Mejia survived the torture, and his horrifying experience ultimately led to Merkel’s arrest.

By late September 1918, news of Merkel’s atroci-

ties reached his regiment and brigade commanders, probably from multiple sources. According to Calder, the Roman Catholic archbishop of Santo Domingo notified Marine authorities of Merkel’s actions after hearing about them from terrified locals.<sup>72</sup> Suarez testified that he never reported Merkel to the authorities because he feared for his life. According to Suarez, Merkel “had several men who used to go around with him [Merkel] in the country . . . and more than one was killed by Captain Merkel himself, because they [the men] had been eyewitnesses to these acts.”<sup>73</sup> Ultimately, a fellow Marine reported Merkel to the authorities, which eventually put a stop to the violence.

After Merkel’s return to Hayto Mayor, Marines of the 52d Company openly talked about what they had done in the interior, sharing their stories with Marines of other companies. A Warrant Officer, Gunner David H. Johns, was appalled by what he heard. On 26 September, Johns reported Merkel to the chain of command. Major R. S. Kingsbury served as the investigating officer and found that

On or about 13 September, on the road between Hayto Mayor and Dos Rios, that the said Merkel did cut off[f] an ear of a native prisoner, name unknown [Mejia], and that he did beat said prisoner with a stick; that the said Merkel did maliciously cause the said prisoner to be cut across the breast and salt to be put in his wounds . . . that this prisoner was by Captain Merkel’s order kept without food or water for a period of at least three days . . . Further, that Captain Merkel did on or about 13 September 1918, unjustifiably cause four native prisoners, names unknown, to be shot down by machine gun and rifle range [sic] . . . And further unlawfully and unjustifiably [b]urned down . . . many houses in Seibo Province, this in direct disobedience of the said Merkel’s orders, received from his commanding officer.<sup>74</sup>

After reading this report, Thorpe ordered Merkel

<sup>67</sup> Ibid.

<sup>68</sup> Ibid.

<sup>69</sup> Ibid.

<sup>70</sup> Ibid.

<sup>71</sup> Ibid.

<sup>72</sup> Calder, “Caudillos and Gavilleros,” 672–73.

<sup>73</sup> Emilio Suarez statement, 1145.

<sup>74</sup> Arrest of Capt Charles F. Merkel, 18 October 1918, geographic files, Dominican Republic 1917–1919, Marine Corps History Division Archives Branch, GRC, Quantico, VA.

to San Pedro de Macorís. On his way there from Hayto Mayor, Merkel went on a final rampage, taking and executing two prisoners near El Higuamo and firing upon laborers who fled from his patrol. On 1 October, Thorpe placed Merkel under arrest.<sup>75</sup> Thorpe, who had brought Merkel into the Marine Corps and supported and praised his tough and thorough nature, placed Merkel in a cell to await court-martial. Thorpe had worked hard to associate the war in Hispaniola with the greater war in Europe. His method of fighting that war, the recontraciones campaign, led to Merkel's downfall.

The next morning around 0930, Private Howard L. Sampson, who served as the sentry over Merkel, heard a pistol shot. Sampson rushed to Merkel's cell and found that Merkel had shot himself in the head.<sup>76</sup> Merkel had acquired a .380 Savage automatic pistol though no one knew where or when he got it. In a report to Commandant Major General George Barnett, Brigadier General Pendleton claimed that Merkel hid the revolver on his person.<sup>77</sup> Marine Corps historians Stephen Fuller and Graham Cosmas take Pendleton at his word.<sup>78</sup> Historians Lester Langley and Ivan Musicant, however, suggest that two Marine officers visited Merkel in his cell the night before and left him the pistol with one round.<sup>79</sup> However, no evidence exists that this occurred. No Marine on guard that day had any knowledge of where the pistol came from. As the ranking officer, Captain Russell Duck, who participated in the killing of Agipito the previous April with Merkel and Taylor, responded to the scene. When Duck arrived, the corporal of the guard handed him Merkel's pistol and a handwritten letter.

Merkel's suicide letter—addressed to his friend, Captain Duck—revealed Merkel as a man who felt betrayed, who believed he had carried out his superior's orders, and who wanted to save the Marine Corps from disgrace. Merkel wrote

I can't bear to think that I shall go to prison after carrying out my CO's [commanding officer's] orders, which were as follows: after the people are concentrated in the various towns designated, everyone found out in the hills will be a bandit unless they have a proper pass. The only way we can settle this revolution is by drastic measures and that is to kill *a whole lot of people*.<sup>80</sup> [emphasis author's]

In the suicide letter, Merkel also claimed that, in a meeting held just before his arrest, he begged Thorpe to admit to ordering Merkel to kill people, but Thorpe refused. Merkel then claimed that "the conversation about killing a lot of people took place at his [Thorpe's] office on the evening of August 19" and that several officers were present.<sup>81</sup> "I am doing this in order to save disgracing the M. Corps and myself," Merkel wrote, "but I sincerely hope that god will punish Thorpe some day for he is not fit to have command of anything and his sole object is to get people into trouble."<sup>82</sup>

Thorpe acted quickly to defend himself and used the fact that Merkel was German to explain his behavior. In the suicide letter, Merkel identified Captain Robert S. Hunter, Lieutenant C. C. Simmons, and Lieutenant Carroll F. Byrd as being present at the meeting when Thorpe gave the order to "kill a whole lot of people." Captain Duck forwarded Merkel's suicide note to Thorpe who then rounded up the officers Merkel mentioned. All the mentioned officers signed documents swearing that Thorpe gave no such order.<sup>83</sup> Thorpe denied all of Merkel's allegations but also tried to explain himself. "As for his [Merkel's] statement that my sole object 'is to get people into trouble,' I presume he [Merkel] refers to numerous prosecutions that I have initiated against Germans . . . I was particularly considerate of the late Captain Merkel and tried to make him a loyal subordinate," Thorpe wrote.<sup>84</sup> Ultimately, everyone

<sup>75</sup> Emilio Suarez statement, 1146.

<sup>76</sup> Charles Merkel files, RG 80 Stack Area IIW3, E-19, General Correspondence, National Archives, Washington, DC.

<sup>77</sup> Joseph H. Pendleton to George Barnett, "Arrest of Captain Charles F. Merkel," 18 October 1918, Charles Merkel personnel files, NPRC, St. Louis, MO.

<sup>78</sup> Fuller and Cosmas, *Marines in the Dominican Republic*, 33.

<sup>79</sup> Langley, *Banana Wars*, 147; and Musicant, *Banana Wars*, 281.

<sup>80</sup> Charles F. Merkel letter to Russell W. Duck, 2 October 1918, Charles Merkel personnel file, NPRC, St. Louis, MO.

<sup>81</sup> Ibid.

<sup>82</sup> Ibid.

<sup>83</sup> George C. Thorpe letter to regimental commander, letter from late Captain Charles F. Merkel, MC, to Captain Russell W. Duck, M. C., 10 October 1918, Charles Merkel personnel file, NPRC, St. Louis, MO.

<sup>84</sup> Ibid.



distanced themselves from Merkel and claimed his actions directly disobeyed orders.

However, Thorpe's behavior calls his innocence and integrity into question. Thorpe's racism, like many Marines stationed in the Dominican Republic and Haiti, tainted his opinions of the population. Regarding Agapito—the Syrian killed by Taylor, Merkel, and Duck in April 1918—Thorpe claimed Agapito and all Syrians in-country “will do anything for money and have no bowels; they are a very low order of humanity.”<sup>85</sup> Believing that Dominicans could not possibly conduct their own campaigns, Thorpe wrote to Pendleton that “the general opinion here is that whoever is running this revolution . . . is getting a lot out of the n—s.”<sup>86</sup> On 14 August, Thorpe praised Merkel claiming “I believe that Captain Merkel and Lieutenant Simmons (commander of 114th Company) are working hard and doing well . . . sympathize with our hard task and be patient with us for we certainly are trying to bring home the black bacon.”<sup>87</sup>

The exact details of what Thorpe said to Merkel and the other officers during the 19 August meeting is unknown. However, Merkel's claim that Thorpe mentioned the need to “kill a lot” is supported by documents. Thorpe wrote those exact words to his own superior on 21 August, two days after the meeting where Merkel claimed Thorpe gave the orders “to kill.”<sup>88</sup> In a letter to Brigadier General Pendleton, Thorpe indicated that he stood to benefit from the deaths of many Dominicans. “If I do a good job of clearing these two provinces of insurgents *and kill a lot* [emphasis author's] maybe I go to a more active field of endeavor too . . . I ought to show that I'd be a good German killer,” Thorpe wrote.<sup>89</sup> He, like many officers, wanted to fight the Germans in France, not wage a frustrating counterinsurgency campaign in what they considered a backwater arena.

Evidence suggests that Thorpe bears at least partial responsibility for the crimes committed under his command. Other officers under Thorpe's command,

such as Taylor and Hatton, also committed atrocities against indigenous people. Thorpe's concentration of Dominicans in urban centers and campaign orders, dated 20 August 1918, gave officers the latitude to abuse Dominicans found outside the designated areas. What is impossible to know is whether or not Thorpe ordered his company commanders to explicitly kill “a lot of people.” On 20 August, he did order his company commanders to “kill the enemy,” but Thorpe also ordered his Marines to “be courteous to everyone. It costs nothing, and it pays well.”<sup>90</sup> Thorpe's letter to Pendleton, however, strongly suggests that Thorpe believed killing Dominicans would lead to positive results, at least for himself. Also, Merkel's murderous and torturous acts against the Dominicans did not occur until after the concentration campaign began and only a few days after Thorpe's letter to Pendleton.

Because of Thorpe, the Marine Corps allowed Merkel to take the blame. Perpetrators of cruelty, of which Merkel serves as a heinous example, inflamed the insurgency and therefore damaged the Marines' ability to accomplish its mission in the Dominican Republic. Thorpe placed the onus for that on Merkel and attributed Merkel's crimes to his German heritage claiming

All insurgents that continued in that state during the past two months have done so because they felt they could not do otherwise as they feared being killed if they surrendered, since they are the criminal class and could expect nothing better than capital punishment if brought to trial; furthermore, they have a fear of being summarily executed . . . This last mentioned belief is founded upon the fact that the late Captain C. F. Merkel, MC, a German, tortured and murdered some prisoners.<sup>91</sup>

At no point did Thorpe take responsibility for actions of the officers under his command—not Taylor, not Hatton, and especially not Merkel. Nor did

<sup>85</sup> Thorpe, “Confidential Report.”

<sup>86</sup> George C. Thorpe to Joseph Pendleton, 18 August 1918.

<sup>87</sup> George C. Thorpe to Joseph Pendleton, 14 August 1918.

<sup>88</sup> George C. Thorpe to Joseph Pendleton, 21 August 1918.

<sup>89</sup> *Ibid.*

<sup>90</sup> George C. Thorpe, “Instructions for Troops in Field against Bandits.”

<sup>91</sup> George C. Thorpe memo to commanding officer, 2d Provisional Brigade, “Observations re Seibo and Maceria Province,” 1918, RG 127, box 8, National Archives, Washington, DC.

Thorpe appear to see the link between his explicit orders to shoot Dominicans attempting to escape and the Dominicans “fear of being summarily executed.”<sup>92</sup>

The Marine Corps was fortunate that the press attributed American victories in France against the German army to Marines, and Merkel’s suicide obviated a court-martial. The cancelled court-martial delayed the promulgation of the atrocities, which proved beneficial to the Corps’ public image and reputation. Had Merkel decided to face a court-martial, he may have defended himself against Thorpe, referring to the facts mentioned in his letter.

A year later, courts-martial of Marines in Haiti for similar crimes brought down a firestorm of negative attention on the 1st Provisional Brigade. In September 1919, Major General Barnett ordered an investigation of Marines in Haiti after he heard of the court-martial of two Marines who killed an indigenous prisoner. Barnett noted that “practically indiscriminate killing of the natives has gone on now for some time.”<sup>93</sup> Newspapers published Barnett’s remarks, which precipitated a barrage of bad press coverage for the Marine Corps. Shortly thereafter, officials opened up investigations of Marine actions in the Dominican Republic.

As a result, in late 1919 and through 1921, U.S. newspapers ran the stories of military misconduct, which caused the publicity nightmare that Marine officials had hoped to avoid. “The military record in Haiti is a blot on the (Woodrow Wilson) administration and a stain on the honor of the American people,” wrote one columnist for the *New York Evening Post*. News of Marines killing Haitian indigenous people indiscriminately “is a shock to those who have cherished the conviction that American military rule did not imitate the coercive methods of some experienced and more callous governments,”

claimed the author (the implication being Germany). The *Philadelphia Public Ledger* reported that “while we [the United States] were ‘making the world safe for democracy’ in France . . . we were ruthlessly practicing machine-gun imperialism.”<sup>94</sup> And regarding the Dominican Republic, the *Cleveland Gazette* ran a story with the headline “Outrage After Outrage Perpetrated in the Little Mulatto Republic, As in Haiti, So in Santo Domingo.”<sup>95</sup> The *Gazette* reporter accused Marines in the Dominican Republic of using “Belgium Congo or Prussian-Belgian methods of eliciting information” such as burning and torturing indigenous people.<sup>96</sup> “I did not meet a single Dominican who did not want the Americans out, band and baggage.”<sup>97</sup>

And in all likelihood, Merkel’s and Thorpe’s actions also fueled resistance to the military government’s political programs in the Dominican Republic. By 1921, indigenous organizations, such as the Antielection League of the Santo Domingo Province, opposed all elections sanctioned by the military government. The league called the Marine occupation of the Dominican Republic “a pirate expedition” that controlled the country “merely by the virtue of their [the Marines’] machine guns and bayonets.”<sup>98</sup> The league accused Marines of hurting, not helping, the Dominican people: “They [the Marines] commit murder, burn, and concentrate the poor peasants of entire regions, depriving them of their lands and water for the benefit of despicable Yankee Corporations.”<sup>99</sup> The description of Marine brutality reflected memories of not only the Tiger of Seibo, Charles Merkel, but also the concentration campaigns of George Thorpe.

The handling of Merkel’s burial indicates the lengths to which the Marine Corps restricted acknowledgement of Merkel’s actions, even among Marines. The Corps shipped Merkel’s body to New

<sup>92</sup> Ibid.

<sup>93</sup> George Barnett confidential letter to John H. Russell, 2 October 1919, *George Barnett Papers*, Marine Corps History Division Archives Branch, GRC, Quantico, VA.

<sup>94</sup> “What Other Papers Say: Puts Nation in Bad Light” *Washington Post*, 16 October, 1920, 6. The paper reported that “Gen. Barnett’s Revelations as to Haiti Held Not an Understatement. Blot on the Administration. Haitian Record Also Seen as Stain on honor of American People. Will Shock Humane Americans. Was Secretary Daniels Deceived? American Cannot afford Oppression. Lodge’s Devotion to Monroe,” *Washington Post*, 16 October 1920, 6.

<sup>95</sup> *Cleveland Gazette*, 25 June 1921, 6.

<sup>96</sup> Ibid.

<sup>97</sup> Ibid.

<sup>98</sup> Anonymous, *Inquiry into the Occupation and Administration of Haiti and Santo Domingo* (statement, Hearings Before the Select Committee on Haiti and Santo Domingo: Pursuant to S. Res. 112, vol. 1, 67th Cong., 1st and 2d sess., December 13, 1921), 1121.

<sup>99</sup> Ibid.

Jersey without a military escort, where he was buried in Hamilton Cemetery, Monmouth County. Hilda Merkel, Charles's sister and closest relative in the United States, was hurt by the perceived slight to her brother and her family's honor.<sup>100</sup> In a letter written to Hilda Merkel, dated 1 November 1918, Brigadier General Charles G. Long expressed regret that Captain Merkel did not receive the honors due to him but noted the Marine Corps' perceived slight was not intentional. "I am very sorry that a misunderstanding arose which led to such a bitter experience for you [Hilda]," he wrote, claiming that the misunderstanding "might have been avoided had your request been directed to these headquarters, in which case an effort would have been made to comply with your wishes."<sup>101</sup> Regarding Hilda's continued inquest into the events leading to her brother's suicide, Long expressed surprise noting, "I am at a loss to suggest any circumstance which should have prompted the act which resulted in his [Merkel's] death."<sup>102</sup>

In mid-November, after learning of the charges against Merkel, Long wrote to Joseph C. Waller, who continued to inquire about Charles Merkel on behalf of his sister. "Your own discretion will dictate what portion of the facts you should communicate to his sister," advised Long.<sup>103</sup> Whether Hilda ever learned of her brother's actions in the Dominican Republic is unknown.

The Marine Corps contacted Hilda at least three more times after 1918 regarding her brother. Apparently, Charles Merkel owed a driver named Melchor Bernol \$75 in transportation fees for several trips made in the summer of 1918 between Hayto Mayor and San Pedro de Macorís. Bernol went to Thorpe for payment; Thorpe paid the man \$50 and had the balance forwarded to Hilda because Thorpe believed the rest should come from Merkel's estate.<sup>104</sup> In 1921 and 1923, respectively, Hilda received her brother's Victory Medal and Mexican Service Badge "to cherish its possession in precious memory of your dear

brother, who died while in the service of his country."<sup>105</sup> Merkel's ambiguous legacy, which has troubled historians since his death, may have begun with those very words.

Merkel's story, like the Marine interventions in Hispaniola, is fraught with ambiguity. In Hispaniola, the Marine Corps gained experience in counterinsurgency warfare, experience that some historians say proved valuable in later small-war conflicts.<sup>106</sup> Some experts argue that Marines accomplished their mission in the country by halting the Dominican Civil War, suppressing organized banditry, protecting American commercial interests, and establishing an indigenous peacekeeping constabulary, the *Guardia Nacional Dominicana*. But these successes came at a cost; many Marines engaged in brutal misconduct of the indigenous population, particularly in the summer of 1918. One historian notes that "it was the style of Marine rule, not its accomplishments, that was remembered," among the Dominicans and among members of the American press.<sup>107</sup>

No Marine encompasses this legacy more than Merkel, whose actions during one summer in the Dominican Republic eclipsed 20 years of honorable service. His superiors often extolled him as an excellent officer. Some of his skirmishes with bandits made positive headlines in U.S. newspapers. However, Merkel is also the Marine Corps' most infamous case of illicit, lurid, and murderous conduct during that occupation. Historians selectively choose parts of Merkel's story when answering questions about the incident. Marines will do the same when figuring out what lessons can be learned from his actions. However, it is important to remember that Merkel did not act alone. Thorpe, Merkel's superior, had a hand in the misconduct, and the Marines' actions were symptoms of institutional problems the Corps faced during World War I.

Merkel and Thorpe represent a dark time in Marine Corps history. *Both* were responsible for some

<sup>100</sup> Hilda Merkel letter to 2d Provisional Regt Headquarters, 30 October 1918, Charles Merkel personnel file, NPRC, St. Louis, MO.

<sup>101</sup> BGen Charles G. Long letter to Hilda Merkel, 1 November 1918, Charles Merkel personnel file, NPRC, St. Louis, MO.

<sup>102</sup> *Ibid.*

<sup>103</sup> BGen Charles G. Long letter to Joseph C. Waller, 13 November 1918, Charles Merkel personnel file, NPRC, St. Louis, MO.

<sup>104</sup> George Thorpe to regimental commander, 28 October 1918, Charles Merkel personnel file, NPRC, St. Louis, MO.

<sup>105</sup> LtCol H. Lay letter to Hilda Merkel, 27 January 1921, Charles Merkel personnel file, NPRC, St. Louis, MO; and LtCol Macker Babb letter to Hilda Merkel, 2 August 1923, Charles Merkel personnel file, NPRC, St. Louis, MO.

<sup>106</sup> James A. Warren, *American Spartans: The U.S. Marines: A Combat History from Iwo Jima to Iraq* (New York: Free Press, 2005), 32.

<sup>107</sup> Langley, *Banana Wars*, 158.

of the worst atrocities committed by Marines in the Dominican Republic, and historians have failed to illuminate the significance of Merkel's and Thorpe's actions. From 1918 until the present, Marine Corps historians have argued that Marines like Merkel represent isolated cases of Marine misconduct in the Dominican Republic. To an extent, this contention is true since most Marines did not commit atroci-

ties while in-country. Atrocities, isolated or not, have a greater impact on the Marines' mission and legacy than the countless number of Marines who served honorably. Merkel's story elucidates the Marine Corps' *Small Wars Manual*, which notes "mistakes may have the most far-reaching effect and it may require a long period to reestablish confidence, respect, and order."<sup>108</sup> ♦ 1775 ♦

---

<sup>108</sup> *Small Wars Manual: U.S. Marine Corps, 1940* (Washington, DC: Government Printing Office, 1940), 32.

# The U.S. Marines in World War I

## PART I: THE U.S. MARINE CORPS RESERVE COMES TO THE FORE

Colonel Walter G. Ford, USMC (Ret)

### America's Citizen Marines—State Militias, a Tradition of National Service

To address more than a century of evolving national requirements, the United States Marine Corps added the crisis response capabilities of the Marine Corps Reserve (Reserve); its origins can be traced to the inadequacies of the states' naval militias for the defense of democracy and protecting the country's interests abroad. The 1916 legislation authorizing a Reserve provided a source of trained manpower and, not surprisingly, was the result of a coordinated Navy-Marine team approach.<sup>1</sup> This first part of a two-part story discusses how the Reserve in World War I depended greatly on the development of Marine branches inside state naval militias, the initiatives authorizing the Reserve and its mobilization, and finally the contributions of the Marine Reserve during the war.

The founding fathers recognized the need for a strong military reserve, but not as it has come to exist. The authors of the Articles of Confederation and later the U.S. Constitution were concerned about possible excesses of a large standing army and its expense on a fledgling nation. Retaining the citizen-soldier character of the military after the American Revolutionary War was fundamental to the survival of the new nation. A small standing army, backed by well-armed and -trained militias provided by the states, offered support for national emergencies.

The U.S. Constitution, which took effect in 1789, addressed the use of state militias with Article I, Section 8, Clause 15, defining the grounds for Congress to call up militias “to execute the laws of the Union, suppress insurrections, and repel invasions.”<sup>2</sup> Then on 2 May 1792, Congress passed the Uniform Militia Act (1 Stat. 264) requiring enrollment in the states militia, specifying exceptions to enrollment and providing guidance on organization and arming of the state militias.<sup>3</sup>

The War of 1812 was the first great test of the militia system. However, when many of the militiamen refused to leave their home states, the militia proved to be of little national value. Militia deployments were not authorized for the Mexican-American War because the conflict did not meet the criteria for employment of state militias as defined in the Constitution, that is to enforce laws, repel invasions, and suppress insurrection. Use of state militias in the American Civil War was more effective—the militias could be used to end insurrections but members were limited to no more than three months active duty.<sup>4</sup>

Secretary of the U.S. Navy Benjamin F. Tracy (1889–93) stressed the importance of a trained militia for the Navy and called for funding arms and equipment for naval militia in various seacoast states. As a result of his efforts with Congress, in his annual report for 1892, Tracy noted the naval appropriation act, approved 19 July 1892, provided \$25,000 for naval militias. In that annual report, he also confirmed qualifying instructions for states seeking a portion of the funds. Seven states formed and mustered in naval militias by the time Tracy

<sup>1</sup> Reserve officers of Public Affairs Unit 4-1, *The Marine Corps Reserve: A History* (Washington, DC: U.S. Government Printing Office [GPO], 1966), 1.

<sup>2</sup> U.S. Const. art. I, § 8, cl. 15. U.S. Constitution Online, [http://www.usconstitution.net/xconst\\_A1Sec8.html](http://www.usconstitution.net/xconst_A1Sec8.html).

<sup>3</sup> Uniform Militia Act of 1792, Pub. L. No. 2-1-28, 1 Stat. 264 (1792).

<sup>4</sup> Rollin F. Van Cantfort, “Call Out the Reserves,” *Marine Corps Gazette* 37, no. 10 (October 1953): 16.

submitted his annual report on 10 December 1892. One additional state mustered in a naval militia unit before the end of the year.<sup>5</sup>

In spite of various congressional actions to improve the state militia system, the Constitutional restrictions on employment of militia remained unchanged, and by the end of the 1898 Spanish-American War, the militia system, which relied on militiamen provided by states, was shown to be inadequate in responding to national emergencies.<sup>6</sup>

## Calls for a National Naval Reserve

The office of the state adjutant general monitored the state militias, including the naval militias. A review of annual adjutant general reports reveals a consensus that improvements were needed in the militia systems.

Of particular note are the difficulties encountered in New York state. In the *Annual Report of the Adjutant General of the State of New York for the Year 1898*, C. Whitney Tillinghast II emphasized a major lesson from the Spanish-American War: the states' abilities to provide forces to support the national call were hindered by the U.S. Constitution's restrictions on the use of militias. Since that war did not meet Constitutional requirements, Tillinghast noted the state of New York was forced to ask its militia for volunteers. While volunteers did come forward, the administrative nightmares associated with reporting the New York militia volunteers "mustering in," or swearing in for federal duty to the satisfaction of the U.S. War Department, were extremely challenging and frustrating, particularly federal payment to the volunteers.

In an exchange of telegrams from May through July 1898, the War Department and the New York adjutant general attempted to sort through the ad-

ministrative issues associated with the expenses of food and shelter, transportation, and pay for the volunteers for federal service.<sup>7</sup>

Additionally, included in the New York adjutant general's 1898 report was the report of the head of the New York Naval Militia, Captain J. W. Miller. Miller wrote on the war with Spain, "The personnel of the Naval Militia is well fitted to defend the immediate coast of the State. If it be desired to perfect the officers and men for deep-sea duty, the general government must provide suitable tools, in the way of modern ships. This has been recommended by me in many annual reports."<sup>8</sup>

Miller added "If the general government provided these ships, it would naturally expect a high standard of excellence both in officers and men. This standard can be obtained by the enactment of a National Naval Reserve Law." He also recommended the National Naval Reserve have its own ranks and ratings and be distinct from the U.S. Navy and that the federal government publish the "scope of examinations for entrance to the Naval Reserve . . . and a certain proportion of the Naval Militiamen of each State should have passed it before any aid was supplied by Congress."<sup>9</sup>

Under President William McKinley's direction, the secretary of the War Department was to procure soldiers from the states' National Guard (NG) units.<sup>10</sup> New York's challenges in responding to federal requests for more manpower were typical of the other states of the Union. More improvements in growing a crisis response capability were needed.

On 1 November 1900, Lieutenant Commander William H. H. Southerland (USN), officer in charge of the Navy Department's Naval Militia Office and future commander of the Navy and Marine force in Nicaragua in August 1912,<sup>11</sup> wrote to the secretary of

<sup>5</sup> U.S. Department of the Navy, *Report of the Secretary of the Navy: Being Part of the Message and Documents Communicated to the Two Houses of Congress at the Beginning of the Second Session of the Fifty-Second Congress* (Washington, DC: GPO, 1892), 44-46.

<sup>6</sup> Van Cantfort, "Call Out the Reserves," 16.

<sup>7</sup> New York's call for volunteers, the very positive response, frustration with the administrative issues, and the exchange of messages between the War Department and New York's state paymaster-general reflects ever increasing annoyance at the federal and state levels and suggests the absence of clearly defined procedures for bringing a militiaman into federal service. See the Adjutant General's Office, State of New York, *Annual Report of the Adjutant-General of the State of New York for the Year 1898* (Albany, NY: Wynkoop Hallenbeck Crawford Co., 1899), 36-43.

<sup>8</sup> Adjutant General's Office, State of New York, *Annual Report of the Adjutant-General of the State of New York for the Year 1898* (Albany, NY: Wynkoop Hallenbeck Crawford Co., 1899), 245-46.

<sup>9</sup> Ibid.

<sup>10</sup> Ibid., 13; and Maj Michael S. Warren, *The National Guard in the Spanish-American War and Philippine Insurrection, 1898-1899* (Ft. Leavenworth, KS: School of Advanced Military, U.S. Army Command and General Staff College, 2012), 12.

<sup>11</sup> George B. Clark, *The United States Military in Latin America: A History of Interventions through 1934* (Jefferson, NC: McFarland & Co., 2014), 117.

the Navy about the inadequacies of the naval militia system:

I call your attention to these facts to show the absolute necessity for the creation, in addition to the naval militia organizations, of a Government or national reserve force, which should be organized entirely under . . . the control of the Navy Department.<sup>12</sup>

Little progress was made in authorizing a reserve for the Navy and Marine Corps until Secretary of the Navy George V. L. Meyer (6 March 1909–4 March 1913) recognized the inadequacies of the militia system as a source of trained officers and men for the Navy and Marine Corps. Meyer twice called for legislation to move toward a viable solution.<sup>13</sup> In December 1911, under his leadership, the Department of the Navy proposed legislation to the 61st Congress (1909–11) to create a “reserve of personnel for the U.S. Navy and Marine Corps and for its enrollment.”<sup>14</sup>

## Need for a Marine Corps Reserve

While the need for a national Navy and Marine Corps reserve force had been building over the years, the operational tempo of the sea services had increased. In particular, the Marine Corps’ operational tempo in Central America, Mexico, and the Caribbean had been expanding since the Spanish-American War. Protecting American interests in Haiti, Veracruz, Nicaragua, and Santo Domingo kept Marines deployed, while manpower had grown only marginally.<sup>15</sup> These demands, plus ships’ detachments, legation guards, and other requirements, strained the Corps’ resources and affirmed the need for a Marine Corps Reserve ready to meet emergent force requirements.

## Marine Militia and National Naval Volunteers

The U.S. Marine Corps Reserve obtained much of its initial core of trained manpower from Marine

units in the state naval militias. Finding records of Marines in state naval militias in the early days of America remains problematic, thus confirming the existence of the first Marine Corps unit in a state militia, after the Naval Appropriations Act of 1892, presents a challenge.

According to available records, the 1st Marine Corps Reserve Company, New York State Naval Militia, was activated in 1893.<sup>16</sup> On 25 January 1994, New York Senator Alfonse M. D’Amato asked for and was granted permission to read into the congressional record part one of a two-part *Naval Reserve Association News* magazine article by two U.S. Navy Reserve/New York Naval Militia officers, Commanders Walter J. Johanson and William A. Murphy, on the history and importance of the naval reserve. It read, in part, as follows:

The Naval Militia, in addition to developing as a reserve for the Navy, was an incipient reserve for the Marine Corps as well. Starting in 1893, the New York Naval Militia included the 1st Marine Corps Reserve Company. Massachusetts and Louisiana also included units of Marines in their Naval Militia organizations.<sup>17</sup>

At the national level, the assistant secretary of war was charged with oversight of the state naval militias from 1891 to 1909. In December 1909, that responsibility was moved to the Personnel Division, Department of the Navy; and in 1911, the Office of Naval Militia was established and assumed oversight and support functions. Then in 1912, the U.S. Naval Militia functions were moved to the Navy’s Bureau of Navigation.<sup>18</sup>

Key references for identifying Marine units in state naval militias include the annual reports of the states adjutants general, which incorporate both national guard and naval militia information. In the annual adjutant general reports of the three states named in the above mentioned article—New York, Massachusetts, and Louisiana—the earliest mentioned Marine unit is in the *Annual Report of the Adjutant General*

<sup>12</sup> *Marine Corps Reserve*, 2.

<sup>13</sup> *Ibid.*

<sup>14</sup> U.S. Department of the Navy, *Annual Reports of the Navy Department for the Fiscal Year 1911* (Washington, DC: GPO, 1912), 56, 63.

<sup>15</sup> Col Jon T. Hoffman, *USMC: A Complete History* (Quantico, VA: Marine Corps Association, 2002), 162–63.

<sup>16</sup> *Marine Corps Reserve*, 3.

<sup>17</sup> 140 Cong. Rec. S (The Naval Militia) (25 January 1994).

<sup>18</sup> “Records of the Bureau of Naval Personnel: Records of the Division of Naval Militia Affairs,” U.S. National Archives Guide to Federal Records, [www.archives.gov/research/guide-fed-records/groups/024.html?vm=r#24.6.2](http://www.archives.gov/research/guide-fed-records/groups/024.html?vm=r#24.6.2).

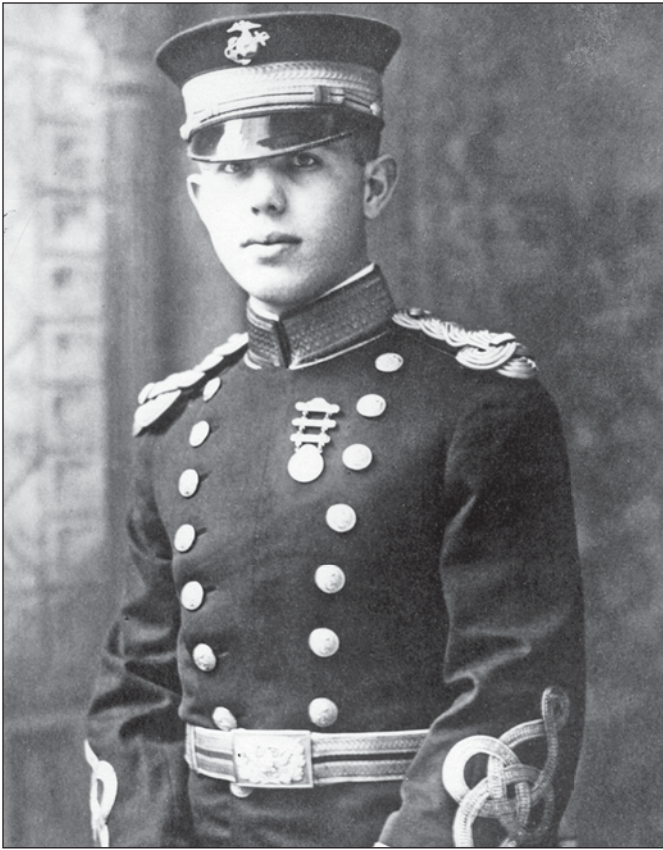

Marine Corps History Division

1stLt William A. Worton, Marine Branch, Massachusetts Naval Militia, in 1916 at age 16.

of the State of Louisiana for the Year Ending 1902. The report lists a Marine guard of 31 men in the 1st Naval Battalion, Louisiana Naval Militia (LNM), serving onboard the USS *Stranger*.<sup>19</sup> The next year, that Marine guard increased to 49 militiamen and reported as Division G, 1st Naval Battalion, Naval Brigade, LNM. The militia continued to increase in number and in 1906, LNM added a second division, Division H, 1st Naval Battalion, Naval Brigade.<sup>20</sup> In a reorganization of the Naval Brigade, Division H was disbanded on 5 September 1912, and the Marine militiamen consolidated into Division G.<sup>21</sup>

In a report ending 31 December 1912, the adjutant general of the Commonwealth of Massachusetts noted the authorization of a Marine guard as part of a new naval militia battalion.<sup>22</sup> In his report the following year, the adjutant general wrote, “For the first time in the history of the Naval Brigade, a Marine guard consisting of 1 commissioned officer and 25 enlisted” was formed.<sup>23</sup>

A charter member of Marine Company, Massachusetts Naval Militia, William A. Worton served more than 30 years on active duty after World War I and retired as a major general in June 1949. His detailed record keeping, personal papers collection, and oral history maintained in the Marine Corps Archives and Special Collections Section of the Marine Corps University provide insight into the organization, arms, equipment, uniforms, and strength of the Marine units in the naval militia prior to and during the war. He mentions the formation of a Marine unit in the Massachusetts Naval Militia in May 1913 with Walter A. Powers, Assistant Attorney General for the Commonwealth of Massachusetts, appointed as a first lieutenant and named as the Marine Company’s first commander.<sup>24</sup> A 1909 Harvard graduate, Powers’s credentials mirror those of many who joined the naval militia: well-educated and upwardly mobile. His militia records indicate he was mustered into the Massachusetts Naval Militia on 11 March 1911 and commissioned first lieutenant 27 March 1913.<sup>25</sup>

Beginning in 1892, the annual reports of the adjutant general of the state of New York included reports from the commander of the naval militia. However, the state’s report does not mention a Marine unit in the state naval militia until the annual report for 1916. That report cites an amendment to the federal law on naval militias approved 15 May 1916, addressing the composition, strength, and command

<sup>19</sup> Louisiana Adjutant General’s Office, *Annual Report of the Adjutant General of the State of Louisiana for the Year Ending 1902* (Baton Rouge, LA: Ramires-Jones Printing Co., 1903), 77–78, filed in The National Guard Memorial Library, Washington, DC.

<sup>20</sup> Louisiana Adjutant General’s Office, *Annual Report of the Adjutant General of the State of Louisiana for the Year Ending 1906* (Baton Rouge, LA: Ramires-Jones Printing Co., 1907), 132–33.

<sup>21</sup> Louisiana Adjutant General’s Office, *Annual Report of the Adjutant General of the State of Louisiana for the Year Ending 1912* (Baton Rouge, LA: Ramires-Jones Printing Co., 1913), 26, 72, 104, 134.

<sup>22</sup> Massachusetts Adjutant General’s Office, *Annual Report of the Adjutant General of the Commonwealth of Massachusetts for the Year Ending December 31, 1912* (Boston, MA: Wright & Potter Printing Co., 1913), 11.

<sup>23</sup> *Ibid.*, 33–34.

<sup>24</sup> William A. Worton, Personal Papers, Marine Corps Archives and Special Collections, Marine Corps University, Quantico, VA.

<sup>25</sup> Massachusetts Adjutant General’s Office, *Annual Report of the Adjutant General of the Commonwealth of Massachusetts for the Year Ending December 31, 1913* (Boston, MA: Wright & Potter Printing Co., 1914), 24.



of the state naval militias. In New York, the 1st Battalion, Naval Brigade, now included nine divisions and an aeronautic section; the 2d Battalion included seven divisions, one Marine company, and one aeronautic section; and the 3d Battalion included eight divisions. According to the 1916 annual report, the naval militia mustered from the Marine Company into the 2d Battalion on 1 May 1916. The company's first commander was Lieutenant J. F. Rorke.<sup>26</sup>

The annual *Register of the Commissioned and Warrant Officers of the Naval Militia of the United States* does not list a Marine unit in any state naval militia until the 1 January 1914 edition, which reported on units that were active in 1913.<sup>27</sup> The sole Marine unit listed in 1914 was Marine Company, Massachusetts Naval Militia, Boston, with 1 officer and 31 enlisted men. A note in the 1914 edition indicates the state of Louisiana did not submit a report for 1913.<sup>28</sup>

## Uniforms of the Marines in the Naval Militia

In a 25 January 1915 letter to U.S. Navy Captain Frederic B. Bassett Jr., chief of the Navy's Division of Naval Militia Affairs, Charles H. Power<sup>29</sup> of 1st Battalion, Naval Militia, New York, asked for clarification on the uniforms, equipment, and ordnance for the state's Marines. His question arose after learning in Washington that "Marines are to be allowed for the Naval Militia, and being about ready to muster in a detachment of one officer and twenty-four men."<sup>30</sup>

Bassett forwarded the letter to Major General Commandant George Barnett on 30 January and stated in his endorsement that appropriations to support the Naval Militia Act would be used to purchase uniforms, equipment, and ordnance for enlist-

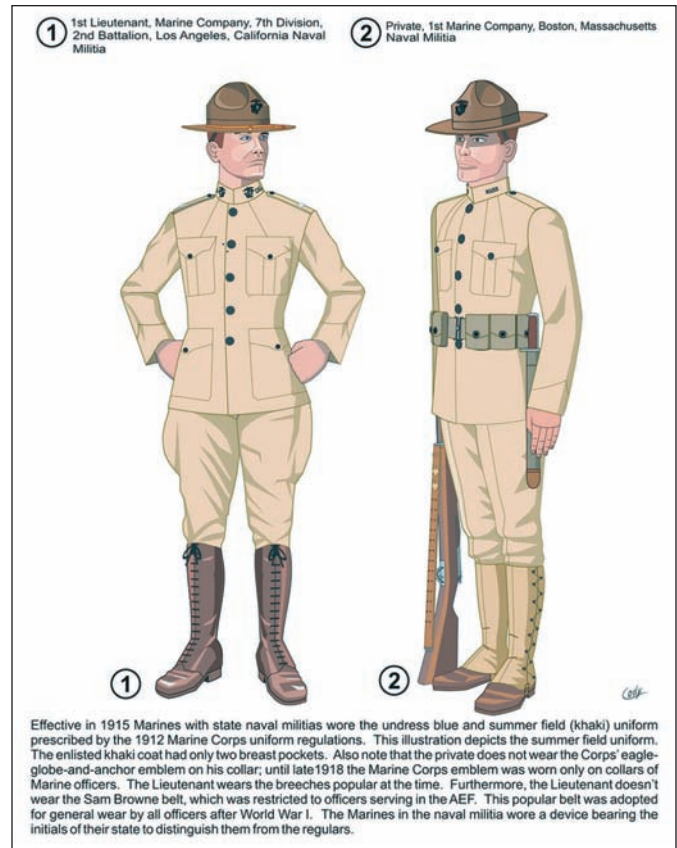

LtCol Richard L. Cody (Ret)  
Uniforms of Marines in the Naval Militia.

ed men, but "no uniforms will be issued to officers, as this is contrary to precedent and there is not sufficient money available." Bassett requested that Barnett define the uniform items and insignia for the Marines in the naval militias.<sup>31</sup>

In a response dated 3 February 1915, Barnett confirmed the enlisted uniform items to be supplied: "khaki, undress blue, campaign hat, undress cap, leggings, flannel shirt, and noncommissioned officers' chevrons, and the regulation tan shoes."<sup>32</sup> He recommended that Marine officers in the naval

<sup>26</sup> New York Adjutant General's Office, *Annual Report of the Adjutant General of the State of New York for the Year 1916* (Albany, NY: J. B. Lyon Co., 1917), 45, 50, 118, 124. The Department of the Navy issued General Order No. 153 implementing the new federal law, and as the states complied with the directive, the composition of their naval brigades adhered to a three-battalion organizational construct. Secretary of the U.S. Navy, U.S. Department of the Navy, *General Orders of the Navy Department: Series of 1913* (Washington, DC: GPO, 1918).

<sup>27</sup> U.S. Department of the Navy, *Register of the Commissioned and Warrant Officers of the Naval Militia of the United States* (Washington, DC: GPO, 1914).

<sup>28</sup> *Ibid.*, 28.

<sup>29</sup> Of note, when war was declared, Power left the naval militia and joined the New York National Guard (NG) in May 1917 and was assigned to the 102d Sanitation Train, 27th Division, NG. He deployed for World War I in June 1918 and returned to Brooklyn, New York, in March 1919 to be discharged. New York State Adjutant General's Office, *Abstracts of National Guard Service in World War I, 1917-1919, Series 13721*, New York State Archives, [http://nysa32.nysed.gov/a/digital/images/about/about\\_military\\_wwi.shtml](http://nysa32.nysed.gov/a/digital/images/about/about_military_wwi.shtml).

<sup>30</sup> Charles H. Power to Capt F. B. Bassett, USN, letter, 25 January 1915, Reserve subject file, Historical Inquiries and Research Branch (HIRB), Marine Corps History Division, Quantico, VA.

<sup>31</sup> Capt Bassett forwarding Power's letter to MajGen Commandant George Barnett, Reserve subject file, HIRB, Marine Corps History Division, Quantico, VA.

<sup>32</sup> Letter from MajGen George Barnett, 3 February 1915, Reserve subject file, HIRB, Marine Corps History Division, Quantico, VA.

militias “be required to equip themselves with khaki and blue, including cap, sword, belt, gloves, leather puttees, campaign hat, etc.” He continued with the following:

It is recommended that Marine officers and enlisted men of the Naval Militia wear the same rank devices and chevrons as in the regular service, and that they wear the Marine Corps insignia, with the same distinguishing mark that may be adopted for the Naval Militia.<sup>33</sup>

## Calls for a United States Marine Corps Reserve

Although more federal funding and equipment were provided to the militia after the Spanish-American War, the militia remained an ineffective solution to a presidential call for forces in time of war. While the inadequacies of the militia system were becoming more apparent at this point, incremental improvements continued.<sup>34</sup> The states’ naval militia organizational efforts progressed significantly with the 16 February passing of the Naval Militia Act of 1914.<sup>35</sup> The act placed the Naval Militia under the supervision of the Department of the Navy, authorizing annual inspections, assigning active-duty naval officers as inspector-instructors for the units, establishing a board to standardize qualifications for all naval militia officers and enlisted men, and elevating the Office of Naval Militia within the Department of the Navy to the larger Division of Naval Militia Affairs under the Bureau of Navigation.<sup>36</sup>

Despite the 1914 Naval Militia Act, the state militia was not seen as the panacea for the ills associated with mobilizing a force in response to a presidential call. Major General Barnett took the oath of office as the 12th Commandant of the Marine Corps on 25 February 1914,<sup>37</sup> just days after passage of the Militia Naval Act. Barnett and Secretary of the Navy Josephus Daniels began a series of meetings from



Library of U.S. Congress, Harris & Ewing Collection  
Secretary of the Navy Josephus Daniels, 1913-21.

which emerged a coordinated plan to increase the size of the Marine Corps and create a Marine Corps Reserve to meet the country’s ever-expanding expeditionary commitments and to provide a source for a manpower surge in the time of war.<sup>38</sup>

A demanding and decisive man of action with a natural bent for seeking efficiencies,<sup>39</sup> Secretary Daniels issued a succinct implementation order for the 1914 Naval Militia Act two months after the legislation passed. In Department of the Navy General Order No. 93 of 12 April 1914, the secretary elevated the importance of the U.S. Naval Militia by enlarging the Office of Naval Militia and renaming it the Division of Naval Militia Affairs.<sup>40</sup> In that order, he also decreed that communications between the states, territories, District of Columbia, and Department of the Navy would be through the new division. That division would be responsible for all business pertaining to the Naval Militia including “armaments,

<sup>33</sup> Ibid.

<sup>34</sup> War College Division, General Staff Corps, *The Militia as Organized Under the Constitution and Its Value to the Nation as a Military Asset*, War Department Document No. 516 (Washington, DC: GPO, 1916), 19.

<sup>35</sup> Naval Militia Act of 1914, Pub. L. No. 63-57, 38 Stat. 283.

<sup>36</sup> Division of Naval Militia Affairs, Navy Department, *Naval Militia Annual Report for the Year 1914* (Washington, DC: GPO, 1915), 3, 4, 72.

<sup>37</sup> LtCol Merrill L. Bartlett, “George Barnett,” in *Commandants of the Marine Corps*, ed. Allan R. Millett and Jack Shulimson (Annapolis, MD: U.S. Naval Institute Press, 2004), 176.

<sup>38</sup> *Marine Corps Reserve*, 4.

<sup>39</sup> Bartlett, “George Barnett,” 181-82.

<sup>40</sup> *General Orders of Navy Department*.

equipment, discipline, training, education, and organization of the Naval Militia.”<sup>41</sup>

Secretary Daniels further interpreted the Naval Militia Act of 1914 in his expansive Navy Department General Order No. 153, wherein he more clearly defined the scope of Marine units in the Marine Corps Branch, Naval Militia, and specified that federal funding was contingent on naval militia units complying with the order’s provisions by 16 February 1917. In General Order 153, dated 10 July 1915, Daniels prescribed a “unit of organization” for the Marine element in the naval militias as a company with 3 officers and 48 enlisted, but noted the companies may be greater or lesser in strength, depending on availability of men. In the 103-page order, he also specified qualification requirements and prerequisites for the different ranks and billets, provided guidance on professional examinations for advancement, and authorized the formation of Marine battalions and brigades, if men were available. The order allowed for honorably discharged Marine veterans to join naval militias without a professional examination.<sup>42</sup>

The secretary moved forward in organizing the naval militias and improving the professional skills of the militia members “in order that they will be eligible to be mustered into the service of the United States without further professional examination on the call of the president.”<sup>43</sup> Barnett continued to press Congress for a ready reserve, noting that manpower was a paramount need and a standing reserve force would be of significant assistance. In his annual report for fiscal year 1915, submitted 1 December, Barnett stated that “The Marine Corps has no reserve. During the last session of Congress a naval reserve, consisting of men who have seen service in the Navy, was created. The adoption of a similar proviso for the Marine Corps is recommended.”<sup>44</sup>

In addition to formal testimonies promoting increased manpower and the creation of a Reserve, efforts moved forward on other fronts with Congress.

In his memoir *The Reminiscences of a Marine*, Major General John A. Lejeune, 13th Commandant of the Marine Corps, tells of becoming the Assistant to the Commandant in January 1915 while a colonel and working to ease the Marine Corps’ manpower deficiencies.<sup>45</sup> General Lejeune noted that “probably the most important” undertaking while he was Assistant to the Commandant was his participation, along with Colonel Charles H. Lauchheimer, on the Navy and Marine Corps Personnel Board. The board worked with the House of Representatives for three months in the summer of 1915 to hammer out the manpower sections of the critically important Naval Appropriations Bill, which later became law.<sup>46</sup>

On 29 February 1916, Barnett, accompanied by Colonel Charles L. McCawley, quartermaster; Colonel George Richards, paymaster; and then-Colonel Lejeune, Assistant to the Commandant, testified before the House Committee on Naval Affairs. In his statement, Barnett once again strongly promoted the need for a Marine Corps Reserve.

Now, Mr. Chairman, I would like to refer to the matter of a Marine Corps reserve. The Marine Corps has no reserve. This is a very important matter, and it is urgently recommended that legislation similar to that enacted for the Navy be also enacted for the Marine Corps. During the last session of Congress the headquarters office of the Marine Corps urgently recommended the incorporation in the naval appropriation bill of a proviso for a Marine Corps reserve, and in the annual report of the Major General Commandant this recommendation was renewed.<sup>47</sup>

## Congress Creates a Marine Corps Reserve

The clarion call by Daniels and Barnett for a formal Reserve was finally heard. On 29 August 1916, the

<sup>41</sup> Ibid.

<sup>42</sup> Ibid., 3, 4, 9.

<sup>43</sup> Ibid., 2.

<sup>44</sup> Navy Department, *Annual Reports of the Navy Department for the Fiscal Year 1915* (Washington, DC: GPO, 1916) 761.

<sup>45</sup> The billet title “Assistant Commandant of the Marine Corps” was first used in October 1946, but in reading Gen Lejeune’s memoir, Lejeune’s duties as Assistant to the Commandant were similar to those of the Assistant Commandant of the Marine Corps. “Marine Corps Assistant Commandants,” HIRB, Marine Corps History Division, [www.mcu.usmc.mil/historydivision/pages/frequently\\_requested/Assistant\\_Commandant.aspx](http://www.mcu.usmc.mil/historydivision/pages/frequently_requested/Assistant_Commandant.aspx).

<sup>46</sup> MajGen John A. Lejeune, *The Reminiscences of a Marine* (Philadelphia: Dorrance and Company, 1930), 219, 227.

<sup>47</sup> *Hearings Before the Committee on Naval Affairs*, House of Representatives, 64th Cong. (29 February 1916) (statement of USMC MajGen Commandant George Barnett), 2143.



*Photo courtesy of Leatherneck magazine*

As a senior colonel and then brigadier general, John A. Lejeune served in the billet of Assistant to the Commandant for MajGen Commandant George Barnett before taking command of Marine Barracks Quantico in September 1917.

Sixty-Fourth Congress, in its first session, authorized a Reserve in H.R. 15947. Specifically, on the creation of the Reserve, the legislation set forth the following:

A United States Marine Corps Reserve, to be a constituent part of the Marine Corps and in addition to the authorized strength thereof, is hereby established under the same provisions

in all respects (except as may be necessary to adapt the said provisions to the Marine Corps) as those providing for the Naval Reserve Force in this Act: *Provided*, That the Marine Corps Reserve may consist of not more than five classes, corresponding, as near as may be, to the Fleet Naval Reserve, the Naval Reserve, the Naval Coast Defense Reserve, the Volunteer Naval Reserve, and the Naval Reserve Flying Corps, respectively.<sup>48</sup>

The legislation addressed the manpower needs of the Navy and Marine Corps and ultimately gave the president more authority to mobilize the U.S. Naval Militia. The congressional work to finally improve the president's access to the Naval Militia also created a new organization, the National Naval Volunteers, into which the president could order members of the Naval Militia and then federalize, or bring onto active service, those trained militiamen for war or other needs. Regarding the National Naval Volunteers, the legislation announced

that to provide a force for use in any emergency, including that of actual or imminent war, requiring the use of naval forces in addition to those of the regular Navy, of which emergency the president shall be, for the purposes of this Act, the sole judge, there is hereby created a force, to be known as the "National Naval Volunteers," into which the President alone is authorized, under such regulations as he may prescribe, to at any time enroll, by commission, warrant, and enlistment, respectively, and without examination, such number as he may decide to enroll from among those of the Naval Militia . . .<sup>49</sup>

The secretary of the Navy moved quickly to publish the legislation through Navy Department channels. General Order No. 231, dated 31 August 1916, reprinted the legislation for the "information and guidance of all persons belonging to the Navy."<sup>50</sup>

While the legislation creating the Marine Corps Reserve directed that it consist of not more than five classes, similar to the Naval Reserve Force, the Ma-

<sup>48</sup> U.S. Congress and Secretary of State, *The Statutes at Large of the United States of America from December, 1915, to March, 1917: Concurrent Resolutions of the Two Houses of Congress and Recent Treaties, Conventions, and Executive Proclamations*, vol. 39, part 1 (Washington, DC: GPO, 1917), 593.

<sup>49</sup> *Ibid.*, 595.

<sup>50</sup> *General Orders of the Navy Department*.

# Classes of Marine Corps Reserve

On 29 August 1916, congressional legislation created the Marine Corps Reserve. Subsequently, Marine Corps Order No. 13, dated 21 March 1917, laid out the implementation of that legislation, creating five classes of Marine reservists for males. Legislation and the Marine Corps order did not address women in the Marine Corps Reserve because Secretary of the Navy Josephus Daniels did not grant the Marine Corps permission to enroll women in the Reserve until 12 August 1918.

## Class 1: Fleet Marine Corps Reserve (FMCR)

- 1a. Officers honorably discharged.
- 1b. Men entitled to an honorable discharge after at least one four-year enlistment.
- 1c. Enlisted men who completed 16 years of honorable service and were transferred to the FMCR at the expiration of enlistment.
- 1d. Enlisted men who completed 20 years of honorable service.

## Class 2: Marine Corps Reserve A

All enrollments were restricted to U.S. citizens, and the commitment was for four years.

- 2a. Officers, provisional: must not be less than 20 or more than 40 years of age; not less than two years' experience as an officer in a military organization or military school or college; and pass a physical and professional examination.
- 2b. Officers, confirmation: after three months active service, must pass another professional examination by a board of officers and a physical examination to retain the provisional rank granted at enrollment.
- 2c. Enlisted men, provisional: must not be less than 18 or more than 35 years of age and of good character and show evidence of abilities.
- 2d. Enlisted men, confirmation: after three months active service, could be confirmed in provisional rank by an appointed Marine Corps officer.

## Class 4: Marine Corps Reserve

This class was for citizens with useful skills and had no age limit. Those enrolled could subsequently transfer to Class 2, if eligible. Often underage or overage men took advantage of this category.

- 4a. Officers, provisional: must show proof of special skills needed in naval and reserve districts and pass a professional and physical examination.
- 4b. Officers, confirmation: same as Class 2, 2b.
- 4c. Enlisted men, provisional: must provide evidence of character and citizenship and proof of needed special skills and pass a medical examination. The provisional rank given was based on skills of the applicant and the requirements of the district.
- 4d. Enlisted men, confirmation: same as Class 2, 2d.

## Class 5: Marine Corps Reserve Flying Corps

Former officers and men of the Marine Corps who were members of the Naval Flying Corps, surplus graduates of the aeronautic school, civilians skilled in flying, building or designing aircraft, and other current members of the Marine Corps Reserve with aviation skills could enter this Marine Corps Reserve class.

- 5a. Officers, provisional: must provide proof of character and citizenship, qualify through a professional examination, and pass a medical examination.
- 5b. Officers, confirmation: honorably discharged former officers of the Naval Flying Corps and surplus graduates of the aeronautical school could be designated in this class without a prior provisional appointment. Marines appointed with a provisional rank must serve three months' active duty service and be confirmed to that provisional rank through a professional examination and a medical examination.

5c. Enlisted men, provisional: must provide proof of character, ability and citizenship and qualify through a professional examination for a provisional rank and pass a medical examination. This class had no age limit.

5d. Enlisted men, confirmation: honorably discharged men of the Naval Flying Corps after at least one four-year enlistment in the Navy and those who were discharged after a term of enlistment. After three months' active duty service, a member could be confirmed in his provisional rank by qualifying before a designated Marine Corps officer.

5e. Any enlisted Marine with 16 years' service could transfer, with the authority of the Major General Commandant, at the end of his current enlistment contract to the Marine Corps Reserve Flying Corps if all other Class 5 requirements were met.

5f. Any enlisted Marine with 20 or more years enlisted service could transfer, with authority of the Major General Commandant, to the Marine Corps Reserve Flying Corps.

### Class 6: Volunteer Marine Corps Reserve

This class was comprised of men who met the qualifications for the above classes and committed themselves but waived their retainer fee and uniform gratuity in time of peace. When called to active duty service in wartime, their pay was the same as the corresponding rank in the Marine Corps.

rine Corps took time to evaluate the next step and did not clarify or define those classes until months later. Marine Corps Order No. 13 (series 1917), dated 21 March 1917, laid out the Marine Corps' expected implementation of that legislation and defined the five classes in the Reserve for men.<sup>51</sup>

The earlier efforts of the members of the Navy and Marine Corps Personnel Board also paid off as an increase in manpower was authorized in the August 1916 legislation. The Marine Corps was granted an immediate increase in officers from 344 to 597, and in enlisted men from 9,921 to 14,981. The legislation also authorized the president to further increase the number of officers to 693 and enlisted men to 17,400 in an emergency.<sup>52</sup>

## Transfer of Personnel of the National Naval Volunteers, Marine Corps Branch, to Marine Corps Reserve

While the intent of the 1916 legislation was to create the Marine Corps Reserve and provide the president access to a trained militia in time of an emergency,

the creation of the National Naval Volunteers caused confusion since both it and the Naval Militia had Marine Corps branches. Congress addressed the issue with an amendment to an appropriations bill for naval services on 1 July 1918, authorizing the president to transfer all personnel of the National Naval Volunteers as a class to the Naval Reserve Force, or the Marine Corps Reserve.<sup>53</sup>

On 10 July 1918, Barnett issued Marine Corps Order No. 34 (series 1918), stating that "from and including July 1, 1918, the personnel of the National Naval Volunteers, Marine Corps Branch, is transferred from that organization to Class 2, Marine Corps Reserve . . ." The order also confirmed that, in accordance with the congressional action, individuals transferred to the Reserve would retain their ranks on a provisional basis. Also, the Reserve would not conduct medical examinations or tests to gauge the professional competence of those brought in via transfer.<sup>54</sup>

Barnett then sent letters to the adjutants general of those states with National Naval Volunteers or Marine branches in their naval militias, informing them of his actions. Those letters, dated 11 July 1918,

<sup>51</sup> Headquarters U.S. Marine Corps, *Revision of U.S. Marine Corps Orders, May, 1918* (Washington, DC: GPO, 1918), hereafter *Revision of U.S. Marine Corps Orders*, 104-20. Among other Marine Corps orders, the reference contains Marine Corps Order No. 13 (series 1917).

<sup>52</sup> Maj Edwin N. McClellan, *The United States Marine Corps in the World War* (Washington, DC: Historical Branch, G-3 Division, Headquarters Marine Corps, 1968), 71.

<sup>53</sup> S. Doc. No. 7983, at 452 (1918).

<sup>54</sup> Commandant of the Marine Corps, U.S. Marine Corps General Order No. 34, 10 July 1918, Reserve subject file, HIRB, Marine Corps History Division, Quantico, VA.



*Marine Corps History Division*

MajGen Commandant George Barnett (1914–20) oversaw the largest expansion in Marine Corps manpower up to that time in the history of the Corps.

went to the nine states with Marine units: California, Illinois, Louisiana, Massachusetts, New York, Ohio, Oregon, Rhode Island, and Texas. The letters noted that should the Marine reservists who entered from state organizations be discharged from the Reserve, the adjutants general would be informed. Barnett then signed a letter that same day to the chief of the Division of Naval Militia Affairs, Bureau of Navigation, Department of the Navy, informing him of the actions to bring the militiamen and National Naval Volunteers into the Reserve.<sup>55</sup>

## The Philadelphia Military Training Corps

Recruiting for the Reserve was slow to begin, hampered by the fact that guidance on the different classes of reserves was not published by the Marine Corps until March 1917. When war was declared on 6 April 1917, the Reserve had just 3 commissioned officers and 36 enlisted men to call for active duty. The Marine Corps Branch of the National Naval Volunteers had 24 officers and 928 enlisted men, also subject to the call for active duty.<sup>56</sup>

However, efforts not associated with the naval militia programs became a valuable source of trained manpower. Civilian military training programs, particularly the Philadelphia Military Training Corps—established with the resources of wealthy, conservative Philadelphian Anthony J. Drexel Biddle—garnered positive Marine Corps exposure and enlistments in the Reserve.

Biddle was among a group of influential individuals who foresaw America's eventual involvement in World War I. In October 1915, with the consent of Barnett, Biddle created a training camp at Lansdowne, Pennsylvania, conducted by Marine noncommissioned officers from Marine Barracks Philadelphia, Pennsylvania. After the close of the camp, Marines from the Philadelphia barracks led periodic drills throughout the winter. Those trained in the camp became known as the “Drexel Biddle Citizens’ Army,” and by April 1916, more than 3,000 men had completed training. At that point, U.S. Representative Thomas S. Butler of Pennsylvania introduced a bill, which was approved, to provide \$31,000 for the Marine Corps to train citizen soldiers.<sup>57</sup>

Also in April 1916, Biddle invited Barnett to speak at a Philadelphia Preparedness Campaign Committee dinner focused on raising money for a citizens’ army. The dinner afforded another opportunity for the Commandant to promote a citizens’ army, reinforcing his quest to pressure Congress into creating a Marine Corps Reserve. Pledging his support for the preparedness campaign, Barnett ordered Captain Logan Feland from Marine Barracks Philadelphia

<sup>55</sup> MajGen Barnett letter to chief of the Division of Naval Militia Affairs, Bureau of Navigation, Department of the Navy, 11 July 1918, Reserve subject file, HIRB, Marine Corps History Division, Quantico, VA. In spite of the legislation and Barnett’s order, some Marines continued to be listed as National Naval Volunteers on unit muster rolls through World War I and during demobilization.

<sup>56</sup> McClellan, *United States Marine Corps in the World War*, 11, 76.

<sup>57</sup> Philadelphia War History Committee, *Philadelphia in the World War, 1914–1919* (New York: Wynkoop, Hollenbeck, Crawford Co., 1922), 81.



*Photo courtesy of Leatherneck magazine*

Logan Feland, as a captain in 1916, was instrumental in successfully recruiting men into the Marine Corps Reserve from the Philadelphia Military Training Corps.

to command training during the summer of 1916 at Lansdowne.<sup>58</sup>

On 23 July, thousands of civilians attended the camp's opening ceremony, and Barnett conducted a formal inspection. At the end of training on 28 August, the Commandant returned to review the graduation parade. During the closing ceremony, Captain Feland called on the graduates to join the Reserve, and 74 percent of the men volunteered.<sup>59</sup>

At age 43, Biddle enrolled as a captain in the Reserve, Class 4, on 31 March 1917, not long before war was declared.<sup>60</sup> By that time, the millionaire sportsman and philanthropist had significantly refined his



*Photo courtesy of Leatherneck magazine*

Anthony J. Drexel Biddle, a millionaire philanthropist who helped form the Philadelphia Military Training Corps prior to WWI, enrolled as a captain in the Marine Corps Reserve in 1917 and taught personal combat techniques until released from active duty in 1919.

combat skills and influenced many of Philadelphia's finest to join the Reserve. One report stated that Biddle's Philadelphia Military Training Corps recruited 40,000 men for the military, including 8,900 for the Marine Corps.<sup>61</sup> Biddle, initially assigned as a bayonet instructor at the new training site, Marine Barracks Paris Island, [sic] South Carolina,<sup>62</sup> (name changed to Parris Island in 1919), became an instructor at the Marine officer training camp at Marine Barracks Quantico, Virginia, by the fall of 1917. While there, he was sent as an observer to study both the French and British close combat training.<sup>63</sup>

Upon his return from Europe in the spring of

<sup>58</sup> David J. Bettez, *Kentucky Marine: Major General Logan Feland and the Making of the Modern USMC* (Lexington: University Press of Kentucky, 2014), 76–77.

<sup>59</sup> *Ibid.*, 78.

<sup>60</sup> U.S. Department of the Navy, *Register of the Commissioned and Warrant Officers of the United States Navy, U.S. Naval Reserve Force and the Marine Corps, January 1, 1919* (Washington, DC: GPO, 1919), 870.

<sup>61</sup> Robert B. Asprey, "The King of Kill," *Marine Corps Gazette* 51, no. 5 (May 1967): 33.

<sup>62</sup> The current Marine Corps Recruit Depot Parris Island was Marine Barracks, Paris Island, SC, in 1917. The spelling changed to Parris Island in May 1919. *Revision of U.S. Marine Corps Orders, MCO No. 27 (Series 1917)*, 129; and Elmore A. Champie, *Brief History of Marine Corps Recruit Depot, Parris Island, South Carolina* (Washington, DC: Historical Branch, G-3 Division, Headquarters, U.S. Marine Corps, 1962), 4.

<sup>63</sup> Asprey, "The King of Kill," 33.



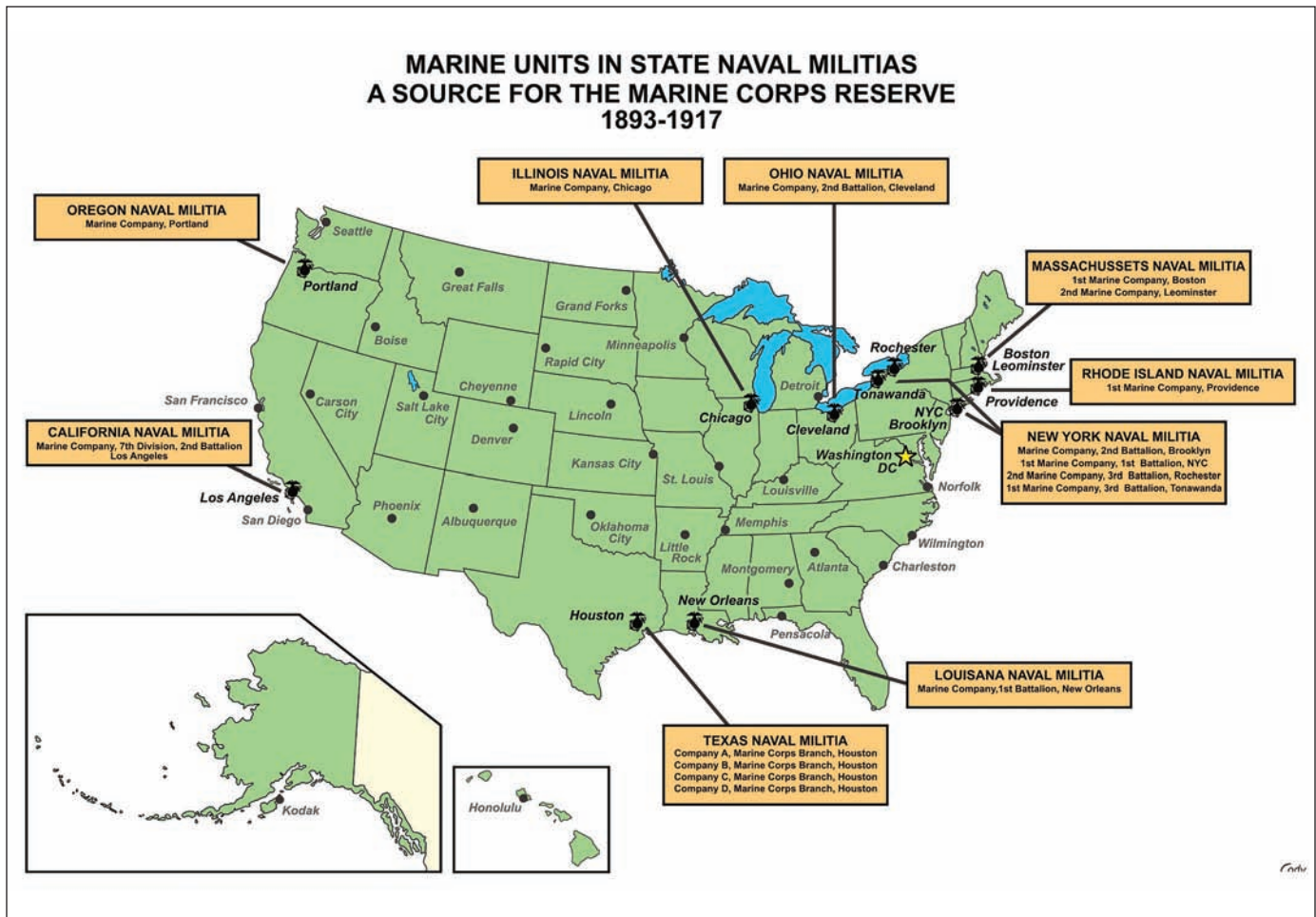

*LtCol Richard L. Cody (Ret)*

Nine U.S. states included Marine Corps units in their naval militias at the beginning of WWI. They were mobilized as National Naval Volunteers (Marines).

1918, Biddle was assigned as an instructor in the Infantry Officers' School at Marine Barracks Quantico, teaching bayonet, knife fighting, and hand-to-hand combat. He continued to prepare officers for war through the Armistice, transferring from Quantico to Marine Barracks Philadelphia on 1 January 1919, where he served as the athletics officer until being released from active duty in July 1919.<sup>64</sup>

Biddle's initiatives promoting civilian readiness indirectly helped to push legislation that created the Reserve and greatly assisted in providing trained manpower for America's war effort. For the next three decades, Biddle continued to serve as a Marine Corps reservist. Biddle returned to active duty briefly in

World War II as a colonel, still spry and effective as an instructor in bayonet fighting, boxing, and jujitsu.<sup>65</sup>

## Mobilization in the Naval Militia, National Naval Volunteers, and Marine Corps Reserve

As America moved toward war, recruitment numbers for the Marine Corps Branch of the Naval Militia topped out at 1,046 men on 1 April 1917. Recruitment for the militia had stopped while recruiting efforts for the Reserve picked up.<sup>66</sup> Just as America declared war on 6 April 1917, the Reserve and Naval Militia mobilized that same day. Nearly all members

<sup>64</sup> "Anthony J. Drexel Biddle," in "Headquarters Detachment, Officers Training Camp, Marine Barracks Quantico, VA, muster roll (MRoll), April-December 1918," "Barracks Detachment, Marine Barracks Philadelphia Navy Yard, PA, MRoll, January 1919," and "Third Reserve District MRoll, July 1919," HIRB, Marine Corps History Division, Quantico, VA.

<sup>65</sup> David J. Bettez, "The Marine Corps Prepares for War: The Philadelphia Military Training Camp," *Leatherneck* 92, no.10 (October 2009), 51.

<sup>66</sup> McClellan, *United States Marine Corps in the World War*, 76.

of the Naval Militia volunteered for enrollment in the National Naval Volunteers.<sup>67</sup> The recruiting environment significantly changed as patriotic fervor spread; three Marine Reserve companies, designated 1st, 2d and 3d Reserve Companies,<sup>68</sup> were immediately recruited in Philadelphia, many most probably sourced from Drexel Biddle Citizens' Army, and began training at the Philadelphia Navy Yard.

### *Militia and National Naval Volunteers*

After members of the state militias and National Naval Volunteers were mustered into federal service, members of the Marine units were ordered to rendezvous sites and then dispatched to various naval stations. Upon arriving at these naval stations, the Marine Corps disbanded the units and men were brought into the Marine Corps and sent to Marine installations to join units based on the needs of the Marine Corps. Some officers in the Marine Corps Reserve and National Naval Volunteers applied for temporary appointments in the regular Marine Corps with the goal of becoming regular active duty officers. Noncommissioned officers were tested and evaluated to confirm their ranks and determine their occupational ratings.<sup>69</sup>

### *Uniforms*

As the Marine Corps grew in numbers with the influx of Marines from the National Naval Volunteers and Reserve, Barnett extended the uniform guidance given to Marines in the state naval militias to Marines serving in the National Naval Volunteers and Reserve.

Marine Corps Order No. 17 (series 1917), signed 14 April 1917, directed that officers and enlisted men of the National Naval Volunteers and the Reserve wear the same uniforms as officers and enlisted men of the regular Marine Corps but with a distinguishing device. Officers in the National Naval Volunteers wore a metal "V" on their coat collars, overcoat shoulder straps, and field hats. Enlisted men of the National Naval Volunteers wore a metal "V" on the field hat. Reserve officers wore a metal "R" on the collars of



*Marine Corps History Division*

After being called to federal service in 1917, 2dLt Newton Best, California Naval Militia (Marines), was assigned as the post athletics officer for Marine Barracks Mare Island.

“undress, white, and field coats and on the shoulder straps of the overcoat.” Reserve officers also wore the metal “R” on “the field hat with the bottom of the letter resting on the top of the hatband” and centered underneath the “eyelet for the corps device.”<sup>70</sup>

### *Training*

With a small Reserve at the beginning of World War I, the multitude of young men who volunteered at the onset of the war overwhelmed the Marine recruit depots. The two Marine Corps recruit training sites for enlisted men—Paris Island [sic] and Mare Island—were initially unprepared for the growth in the number of recruits. While the facilities were being expanded, a temporary recruit depot with capacity for 2,500 recruits was established at the Philadelphia Navy Yard. Another temporary recruit training facility with a capacity for 500 opened at the Norfolk Navy Yard. By the end of the war, the Marine Corps had significantly enlarged both primary recruit

<sup>67</sup> U.S. Department of the Navy, *Annual Reports of the Navy Department for the Fiscal Year 1917* (Washington, DC: GPO, 1918), 25.

<sup>68</sup> “United States Reserve, 1914–1940,” a summary paper, Reserve subject file, HIRB, Marine Corps History Division, Quantico, VA.

<sup>69</sup> “Marine Corps Militia,” *Marine Magazine*, July 1917, 4.

<sup>70</sup> *Revision of U.S. Marine Corps Orders*, 125.

Table 1. Marine Corps Reserve Units Activated for the First World War

Unit	Activated	Commander	Location
Marine Company, 7th Division, 2d Battalion, California Naval Militia became 36th Company	6 April 1917	Capt Newton Best	Exposition Park, Los Angeles moved to Marine Barracks Mare Island, California <sup>71</sup>
Marine Company, 1st Battalion, Louisiana Naval Militia, New Orleans	6 April 1917	Capt Sidney S. Simpson	Marine Barracks Naval Station New Orleans <sup>72</sup>
1st Marine Company, Massachusetts Naval Militia, Boston	27 March 1917	Capt George H. Manks	Charlestown (Boston) Navy Yard <sup>73</sup>
2d Marine Company, Massachusetts Naval Militia, Leominster, Massachusetts	9 May 1917	1stLt James R. Walsh (discharged 18 June 1917)	Charlestown (Boston) Navy Yard <sup>74</sup>
Marine Company, 2d Battalion, New York Naval Militia, Brooklyn	6 April 1917	1stLt James F. Rorke	Northport, New York, power station <sup>75</sup>
1st Marine Company, 1st Battalion, New York Naval Militia, New York City	26 April 1917	1stLt Stanford W. Hoffman	Marine Barracks Brooklyn Navy Yard, New York <sup>76</sup>
1st Marine Company, 3d Battalion, New York Naval Militia, Tonawanda	7 April 1917	1stLt Alan V. Parker	Marine Barracks Brooklyn Navy Yard <sup>77</sup>
2d Marine Company, 3d Battalion, New York Naval Militia, Rochester	7 May 1917	2dLt Clarence Ball	Marine Barracks Brooklyn Navy Yard <sup>78</sup>
Marine Company, 2d Battalion, Ohio Naval Militia, Cleveland	7 April 1917	1stLt Jonas H. Platt	Marine Barracks Brooklyn Navy Yard <sup>79</sup>
Marine Company, Oregon Naval Militia, Portland	6 April 1917	2dLt Richard I. Heller	Marine Barracks Puget Sound Navy Yard, Washington <sup>80</sup>
Company A, Texas Naval Militia	6 April 1917	Capt Thomas R. Shearer	Marine Barracks Pensacola, Florida <sup>81</sup>
Company B, Texas Naval Militia	6 April 1917	Capt Percy D. Cornell	Marine Barracks Pensacola, Florida <sup>82</sup>
Company C, Texas Naval Militia	6 April 1917	Capt William N. Pearson	Marine Barracks Charleston Navy Yard, South Carolina <sup>83</sup>
Company D, Texas Naval Militia	6 April 1917	Capt Angus A. Acree	Marine Barracks Norfolk Navy Yard, Virginia <sup>84</sup>
1st Marine Company, Rhode Island Naval Militia, Providence	6 April 1917	Capt John H. Sadler	Marine Barracks Boston Navy Yard <sup>85</sup>
Marine Company, Illinois Naval Militia, Chicago	6 April 1917	Capt Franklin T. Steele	Marine Barracks Philadelphia Navy Yard <sup>86</sup>

<sup>71</sup> Department of the Navy, *Register of the Naval Militia of the States, Territories, and of the District of Columbia, January 1, 1917* (Washington, DC: GPO, 1917), 228, and "National Naval Volunteers (MC), 36th Company, Marine Barracks Mare Island, CA MRoll, 6 April-30 April 1917," and "98th Company, Marine Barracks Mare Island MRoll, 1 September-30 September 1917," HIRB, Marine Corps History Division.

<sup>72</sup> "Louisiana Company, National Naval Volunteers (MOB) MRoll, 6 April-30 April 1917," HIRB, Marine Corps History Division.

<sup>73</sup> LtCol Eben Putnam, A. of U.S., ed., *Report of the Commission on Massachusetts' Part in the World War: History, vol. 1* (Boston, MA: The Commonwealth of Massachusetts, 1931), 28; and "1st Marine Company (Mass.), National Naval Volunteers MRoll, 7 April-30 April 1917," HIRB, Marine Corps History Division.

<sup>74</sup> *Ibid.*, 155-56; and James R. Walsh, Officers' Data Card, Archives-Museum Branch, The Adjutant General's Office, Concord, MA.

<sup>75</sup> "New York Company, National Naval Volunteers MRoll, 6 April-11 April 1917," HIRB, Marine Corps History Division.

<sup>76</sup> "Eastern Recruiting Division MRoll, 1 November-30 November, 1917," HIRB, Marine Corps History Division, Quantico, VA; and New York Adjutant General, *Annual Report of the Adjutant General of The State of New York, 1917* (Albany, NY: J.B. Lyon Co., 1920), 20.

<sup>77</sup> "1st Marine Company, 3d Battalion, National Naval Volunteers, Tonawanda, NY MRoll, 7 April-7 May 1917," HIRB, Marine Corps History Division.

<sup>78</sup> "2d Marine Company, 3d Battalion, National Naval Volunteers, Rochester, NY MRoll, 6 April-6 May 1917," HIRB, Marine Corps History Division.

<sup>79</sup> "Ohio Company, National Naval Volunteers, Marine Barracks New York MRoll, 7 April-30 April 1917," HIRB, Marine Corps History Division.

<sup>80</sup> Oregon Secretary of State, *Oregon Blue Book, 1917-1918*, compiled by Ben W. Olcott, Secretary of State (Salem, OR: State Printing Department, 1918), 114; and "Marine Corps Militia," *Marine Magazine*, July, 1917, 4.

<sup>81</sup> "Company A, Texas National Naval Volunteers MRoll, 12 April-30 April 1917," HIRB, Marine Corps History Division.

<sup>82</sup> "Company B, Texas National Naval Volunteers MRolls 7 April-30 April 1917 and 1 May-4 May 1917," HIRB, Marine Corps History Division.

<sup>83</sup> "Company C, Texas National Naval Volunteers MRoll 6 April-30 April 1917," HIRB, Marine Corps History Division.

<sup>84</sup> "Company D, Texas Naval Militia (Marine Corps Branch) MRoll 6 April-30 April 1917," HIRB, Marine Corps History Division.

<sup>85</sup> "1st Marine Company, (R.I.), National Naval Volunteers MRoll 7 April-30 April 1917," HIRB, Marine Corps History Division.

<sup>86</sup> "Marine Company, National Naval Volunteers, 1st Regiment, Marine Barracks Navy Yard Philadelphia MRoll 9 April-30 April 1917," HIRB, Marine Corps History Division.

## Clarence Ball

Clarence Ball, a member of the Sons of the American Revolution, Empire State Society<sup>1</sup>, enlisted in the New York Naval Militia in Rochester in 1892 and served as a petty officer in the U. S. Navy during the Spanish-American War, was promoted to first lieutenant in the Marine Corps Branch, New York Naval Militia in August 1917 and ordered to the officers training camp in Quantico, Virginia. He joined the 5th Regiment in France in June 1918 in time for the beginning of the battle of Belleau Wood on 6 June. Ball fought at Soissons, the Saint-Mihiel salient, and the Champagne sector. During the battle of Blanc Mont Ridge, he assumed command of Company M, 5th Regiment, after the commanding officer was wounded and evacuated. Hospitalized for wounds received during his time in the Champagne sector, Ball yielded command in early November 1918 and was evacuated back to the United States.<sup>1</sup>

Ball was cited for gallantry in action while serving with the 5th Regiment (Marines), 2d Division, American Expeditionary Forces, at Château-Thierry, France, 6–10 July 1918 and authorized to wear a silver star “on the ribbon of the Victory Medals awarded him.”<sup>2</sup> Ball was honorably discharged from the Marine Corps Reserve on 6 October 1919 as a captain.<sup>3</sup>

<sup>1</sup> Edward R. Foreman, ed., *World War Service Record of Rochester and Monroe County New York*, vol. 2, *Those Who Went Forth to Serve* (Rochester, NY: City of Rochester, 1928), 58.

<sup>2</sup> “Clarence Ball,” Hall of Valor, <http://valor.militarytimes.com/recipient.php?recipientid=75048,1910>.

<sup>3</sup> “Barracks Detachment, Marine Barracks Quantico, VA, MRoll, 1 October–31 October 1919,” roll 0181, ancestry.com.

training facilities and set the duration of training at eight weeks.<sup>87</sup>

The Marine Corps pursued officers differently. Before legislation authorized the formation of a Reserve in August 1916, Commandant Barnett brought 18 of the best Marine noncommissioned officers to Washington, DC, for officer testing. On 7 August, 12 enlisted Marines passed the exam. After legislation for the Reserve was approved, the Commandant sent a letter to colleges with military training curriculums offering graduates the opportunity to take an examination on 18 September 1916 to become a Reserve officer. Only 24 candidates passed the exam, so the Commandant offered a second examination (military training was not necessary) in November 1916 for any civilian.<sup>88</sup>

Officers appointed directly from civilian life went to the Marine barracks at Mare Island and San Diego, California; the Marine Corps Rifle Range Winthrop, Maryland; and Paris Island<sup>89</sup> [sic] until the Officers Camp of Instruction could be opened at Marine Barracks Quantico. The first contingent of 345 untried, new lieutenants arrived at Quantico in July 1917.<sup>90</sup>

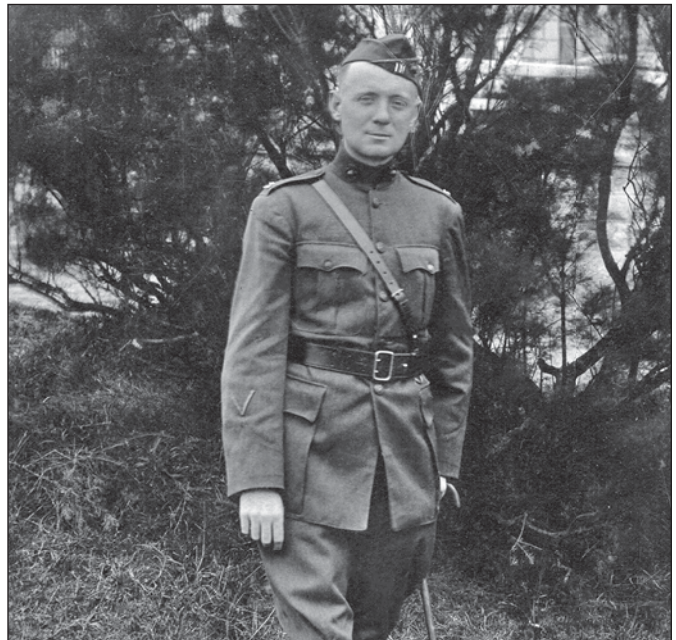

Marine Corps History Division

Capt Jonas H. Platt resigned from the National Naval Volunteers to accept a regular commission in the Marine Corps in September 1917. He earned a Navy Cross and a Purple Heart in the battle of Bois de Belleau on 6 June 1918.

<sup>87</sup> McClellan, *United States Marine Corps in the World War*, 25.

<sup>88</sup> Bernard C. Nalty and LtCol Ralph F. Moody, *A Brief History of U.S. Marine Corps Officer Procurement, 1775–1969* (Washington, DC: Historical Division, HQMC, 1958, rev. ed. 1970), 4.

<sup>89</sup> McClellan, *United States Marine Corps in the World War*, 22.

<sup>90</sup> LtCol Charles A. Fleming, Capt Robin L. Austin, and Capt Charles A. Braley III, *Quantico: Crossroads of the Marine Corps* (Washington, DC: History and Museums Division, HQMC, 1978), 26.



*Marine Corps History Division*

John W. Thomason Jr. enlisted as a private in the Texas Naval Militia, mobilized as a gunnery sergeant with Company A, Texas Naval Militia, then commissioned in Company C. He gained fame as an author and illustrator and passed away in 1944 as a Marine colonel.

In June 1917, after success in these early efforts, the Commandant issued Marine Corps Order No. 25 (series 1917), discontinuing the enrollment of civilians because he believed this source for officers was no longer required. Instead, the Marine Corps would appoint graduates of the U.S. Naval Academy and enlisted men who distinguished themselves in active service.<sup>91</sup>

In April 1917 at the beginning of U.S. involvement



*Marine Corps History Division*

Capt Franklin T. Steele, Naval Militia Illinois, accepted a regular commission in the Marine Corps and served in the Heavy Artillery Force, Marine Barracks Quantico during WWI.

in World War I, more than 50 percent of active duty U.S. Marines (13,725) were serving outside the continental United States, either onboard U.S. Navy ships (2,236) or ashore (4,733).<sup>92</sup> With the adopted slogan of "First to Fight," the Marine Corps quickly carved out the 7th, 8th, and 9th Regiments for the continuing commitments of the Advanced Base Force, with all remaining regiments intended for the American Expeditionary Forces (AEF).<sup>93</sup>

At that time, Marine Corps manpower was stretched. However, with the assistance of the emerging Reserve and National Naval Volunteers, the Marine Corps filled a request from Secretary of War

<sup>91</sup> Revision of U.S. Marine Corps Orders, 128; and Nalty and Moody, *A Brief History of U.S. Marine Corps Officer Procurement*, 76.

<sup>92</sup> McClellan, *United States Marine Corps in the World War*, 9, 11.

<sup>93</sup> Col Robert Debs Heinl Jr., *Soldiers of the Sea: The United States Marine Corps, 1775-1962* (Annapolis: U.S. Naval Institute, 1962), 193.



*Library of Congress, Harris & Ewing Collection*

MajGen Commandant George Barnett inspects the sights and action of a Lewis machine gun at the Marine Corps Rifle Range Winthrop, MD, in 1917.

Newton D. Baker Jr. for a regiment of Marines to be part of the AEF in France. Within weeks, the Marine Corps' 5th Regiment sailed from Philadelphia.<sup>94</sup>

The regiment officially organized at the Philadelphia Navy Yard on 7 June 1917, just one week prior to departing for France on 14 June.<sup>95</sup> Commanded by Colonel Charles A. Doyen, the regiment consisted of 70 officers and 2,689 enlisted men<sup>96</sup> drawn from ship detachments, naval stations, and barracks plus newly enlisted men from the Reserve and National Naval Volunteers.<sup>97</sup> The Reserve was of critical importance when the Marine Corps was called to war quickly; for example, 75 of the 123 Marines of the regiment's Supply Company were reservists. Most of these men came from 1st and 2d Marine Reserve Companies

in training in Philadelphia.<sup>98</sup> The June muster rolls for 5th Regiment units included 16 Reserve officers, 1 officer in the National Naval Volunteers, Marine Branch, 88 Reserve enlisted men, 74 enlisted men in the National Naval Volunteers, and 2 enlisted men in the U.S. Naval Militia, Marine Branch, who had not yet been brought into the National Naval Volunteers.<sup>99</sup>

Many reservists and National Naval Volunteers in the AEF ground forces in France were in units of the 4th Brigade, 2d Division.<sup>100</sup> The brigade earned honors from actions taken in the Aisne defensive and the battles at Hill 142, Bouresches, and Belleau Wood—which garnered international recognition for U.S. Marines—and at Soissons, Saint-Mihiel,

<sup>94</sup> George B. Clark, *Devil Dogs: Fighting Marines of World War I* (Novato, CA: Presidio Press, Inc., 1999), 2-3.

<sup>95</sup> *Ibid.*, 2.

<sup>96</sup> McClellan, *United States Marine Corps in the World War*, 9.

<sup>97</sup> Clark, *Devil Dogs*, 2.

<sup>98</sup> "Supply Company, 5th Regiment, onboard USS *Hancock*, MRoll, 12 June-30 June 1917," HIRB, Marine Corps History Division, Quantico, VA.

<sup>99</sup> "5th Regiment Field and Staff MRoll, 8 June-30 June 1917" and the muster rolls of "Headquarters Company, 5th Regiment; Supply Company, 5th Regiment" and the companies of "1st Battalion, 5th Regiment, 2d Battalion, 5th Regiment and 3d Battalion, 5th Regiment, June 1917," HIRB, Marine Corps History Division, Quantico, VA.

<sup>100</sup> "2d Division General Recapitulation MRoll, 1 November-30 November 1918," HIRB, Marine Corps History Division, Quantico, VA.



Library of Congress, Charles Buckles Falls,  
World War I Posters Collection

*Premiers au feu* means "First to Fight" in English, and the Marines meant to live up to that reputation by getting to France with the American Expeditionary Forces in June 1917.

Blanc Mont, the crossing of the Meuse River, and during the occupation of Germany, all of which motivated U.S. Marines and instilled the Marine Corps in the hearts of Americans.

## The Marine Corps Reserve during the War but Not "Over There"

While most of the mobilized Marine Corps Reserve, U.S. Naval Militia, and National Naval Volunteers were deployed with units in France, many remained in the United States at bases and stations, some were

in U.S. Navy ships' detachments and others were with Marine units scattered around the globe.

As America's involvement in World War I became unavoidable, bands of rebels created unrest and disturbed sugar production in Cuba. As early as March 1917, Marines deployed from Haiti to Cuba to ensure the continued safety of the Allied sugar supply. With continued disruption of sugar-producing efforts and an outcry from American sugar producers, the Marine Corps activated the 7th Regiment, one of the Advanced Base Force regiments, in Philadelphia on 14 August 1917 under Lieutenant Colonel Melville J. Shaw.<sup>101</sup> The regiment arrived in Guantanamo Bay, Cuba, on 27 August 1917.<sup>102</sup>

With significant efforts to assemble a fighting force for Europe, filling out the 7th Regiment for Cuba required Reserve participation, specifically for the headquarters company. Marine regiments, at this time, were not organized in battalions but were formed for expeditionary service with a headquarters and a varying number of companies based on the need.<sup>103</sup> The 7th Regiment included a headquarters company and eight infantry companies. Of the 120 men in Headquarters Company, 7th Regiment, 42 were reservists and all transferred in from the 1st Marine Reserve Company, Marine Barracks Philadelphia.<sup>104</sup> The eight companies in the regiment—37th, 59th, 71st, 72d, 86th, 90th, 93d, and 94th—were less dependent on the Reserve for men. However, two of the three officers in each company were reservists except in 59th Company, which had one Marine Corps Regular, one Reserve, and one officer from the National Naval Volunteers.<sup>105</sup>

Oil was another resource critical to the Allied war effort. The U.S. Navy and Allies were dependent on the Mexican oil fields, but deteriorating relations and continued turmoil in Mexico in 1917 caused concern about undisrupted oil supply. The infamous "Zimmermann Telegram" prompted action.<sup>106</sup> To ensure the flow of oil from Mexico and to promote stability

<sup>101</sup> James S. Santelli, *A Brief History of the 7th Marines* (Washington, DC: History and Museums Division, HQMC, 1980), 1.

<sup>102</sup> J. Robert Moskin, *The U.S. Marine Corps Story*, 3d rev. ed. (Boston, MA: Little, Brown and Company, 1992), 156; and "Headquarters, 7th Marine Regiment MRoll, 14 August–31 August 1917," HIRB, Marine Corps History Division, Quantico, VA.

<sup>103</sup> James S. Santelli, *A Brief History of the 8th Marines* (Washington, DC: History and Museums Division, HQMC, 1976), 1–2.

<sup>104</sup> "Headquarters, 7th Marine Regiment MRoll, 14 August–31 August 1917," HIRB, Marine Corps History Division.

<sup>105</sup> "37th, 59th, 71st, 72d, 86th, 90th, 93d, and 94th Companies, 7th Marine Regiment, USMC, MRoll, 1–31 August 1917," HIRB, Marine Corps History Division, Quantico, VA.

<sup>106</sup> Communiqué from the German foreign secretary, Arthur Zimmermann, to the German ambassador to Mexico that promised significant financial support to Mexico if it allied with Germany against the United States. BGen Edwin Howard Simmons and Col Joseph H. Alexander, *Through the Wheat: The U.S. Marines in World War I* (Annapolis: U.S. Naval Institute Press, 2008), 2.



Library of Congress, United States Army Signal Corps  
Marines in France dig trenches during training for battle.

in relations with Mexico, once again the president turned to the Marine Corps for a ready reserve force, and the Corps responded with the 8th Regiment.

The 8th Regiment of the Advanced Base Force was activated at Marine Barracks Quantico on 9 October 1917 under the command of Major Ellis B. Miller. The 8th Regiment became an infantry regiment with a headquarters and three companies—105th, 106th, and 107th. Within the month, it added 103d, 104th, 108th, 109th, and 110th Companies from Marine Barracks Mare Island, and two additional companies were organized from men at Marine Barracks Quantico—111th and 112th Companies.<sup>107</sup> Once again, the Reserve helped the Corps quickly field the new regiment. The regiment's Headquarters Company stood up on 9 October with 39 men on its muster roll, 20 of whom were reservists.<sup>108</sup> Each of the companies, except the 109th and 111th, included Marine

Corps reservists and National Naval Volunteers.<sup>109</sup>

On 2 November 1917, Colonel Laurence H. Moses arrived at Quantico from Marine Barracks New York and assumed command of the regiment the next day. Then, exactly one month after being activated, the 8th Regiment boarded USS *Hancock* (AP 3) and, on 10 November 1917, sailed for Fort Crockett, Texas, on Galveston Island and arrived on 18 November.<sup>110</sup> The regiment's mission was to prepare to move swiftly to land on the Mexican coast and seize the major oil fields near Tampico, Mexico. The 8th Regiment, joined by 9th Regiment in August 1918, remained at Fort Crockett under the command of 3d Provisional Brigade until early 1919.<sup>111</sup>

The third regiment intended for the Advanced Base Force—the 9th Regiment—was formed at Marine Barracks Quantico on 20 November 1917 with a headquarters, one machine gun company, the 14th

<sup>107</sup> Santelli, *A Brief History of the 8th Marines*, 1.

<sup>108</sup> "Headquarters Company, 8th Marine Regiment MRoll, 9-31 October 1917," HIRB, Marine Corps History Division, Quantico, VA.

<sup>109</sup> "103d, 104th, 105th, 106th, 107th, 108th, 109th, 110th, 111th, and 112th Companies, 8th Marine Regiment, USMC MRoll, 1-31 October 1917," HIRB, Marine Corps History Division, Quantico, VA.

<sup>110</sup> "Headquarters Company, 8th Marine Regiment MRoll, 1-30 November 1917," HIRB, Marine Corps History Division, Quantico, VA.

<sup>111</sup> Santelli, *A Brief History of the 8th Marines*, 2.





*Library of Congress, Harris & Ewing Collection*

Secretary of the Navy Josephus Daniels visits Marines during training at the newly activated Marine Barracks Quantico in 1918.

Company, and eight rifle companies—36th, 100th, 121st, 122d, 123d, 124th, 125th, and 126th.<sup>112</sup> Again, the Reserve and the National Naval Volunteers played a key role. The headquarters of the newly formed 9th Regiment had 22 men on its muster roll on the day the regiment was activated, and 19 were Marine Corps reservists.<sup>113</sup> On 20 November, the 36th Company, 9th Regiment, had 4 Marine Corps reservists and 41 National Naval Volunteers to a total strength of 117 men.<sup>114</sup> While the 100th Company reported only 1 Marine Corps reservist and 7 National Naval Volunteers to a strength of 111 men,<sup>115</sup> the remaining five companies, 121st through 126th, reported no Marine Corps reservists or National Naval Volunteers on their muster rolls.<sup>116</sup>

## Numbers Reflect Wartime Significance of the Reserve

An examination of the “General Recapitulation” of the Marine Corps’ November 1918 muster rolls for the 4th Brigade, 2d Division, AEF, reveals that 28.9 percent (86 of 212) of the officers and 11 percent (1,040 of 8,372) of the enlisted men in the brigade were Marine Corps reservists.<sup>117</sup> In that month, November 1918, the Reserve attained its highest strength: 6,773.<sup>118</sup>

Certainly the Reserve suffered its share of casualties in a war where the Marine Corps endured more casualties in eight months than during its entire 142 years of existence.<sup>119</sup> In February 1919, Barnett re-

<sup>112</sup> Truman R. Strobridge, *A Brief History of the 9th Marines* (Washington, DC: Historical Branch, G-3 Division, HQMC, 1967), 1.

<sup>113</sup> “Headquarters, 9th Marine Regiment MRoll, 20 November–30 November 1917,” HIRB, Marine Corps History Division.

<sup>114</sup> “36th Company, 9th Marine Regiment MRoll, 20 November–30 November 1917,” HIRB, Marine Corps History Division.

<sup>115</sup> “100th Company, 9th Marine Regiment MRoll, 1 November–30 November 1917,” HIRB, Marine Corps History Division.

<sup>116</sup> “121st, 122d, 123d, 124th, 125th, and 126th Companies, 9th Marine Regiment MRoll, 1 November–30 November 1917,” HIRB, Marine Corps History Division.

<sup>117</sup> “2d Division General Recapitulation MRoll, 1 November–30 November 1918,” HIRB, Marine Corps History Division.

<sup>118</sup> McClellan, *United States Marine Corps in the World War*, 76.

<sup>119</sup> Heinl, *Soldiers of the Sea*, 219.

ported that 7 Marine Reserve officers and 156 enlisted men were killed in action, and 8 Reserve officers and 61 enlisted men died of other causes. The 6,435 Marines reported wounded were not separated by component, Regular or Reserve, so a definite look at this measure of sacrifice for the Reserve is not possible.<sup>120</sup>

The deaths reflect the sacrifice and commitment of Marine Corps reservists. The decorations awarded to reservists punctuate the significance of the contributions the Reserve made to the war effort. One Marine reservist, Second Lieutenant Ralph Talbot, earned the Medal of Honor. Forty Marine reservists or Marines enrolled via the Naval Militia or National Naval Volunteers were awarded the Navy Cross with many also earning a Distinguished Service Cross for the same actions.<sup>121</sup> Captain Percy D. Cornell, who entered the Marine Corps via the Texas Naval Militia, Marine Branch, was awarded the Navy Cross twice for separate actions.<sup>122</sup>

Private Roy H. Simpson, who joined the Reserve in Philadelphia assigned to 1st Reserve Company, Marine Barracks Philadelphia,<sup>123</sup> was awarded a Navy Cross for heroic actions while serving with the 47th Company, 5th Regiment, during the attack on Belleau Wood. On 12 June 1918, Simpson was carrying a message from battalion headquarters to his company when he was apparently shot. Initially reported as killed in action and posthumously awarded the Navy Cross,<sup>124</sup> Simpson was actually a prisoner of war being held at Rastatt, Baden, Germany. He was released on 6 December 1918 and returned to his unit in France on 19 January 1919.<sup>125</sup>

Several Marine reservists were awarded Navy Distinguished Service medals in addition to the Navy Cross, but only one Marine reservist was recognized

solely with the Navy Distinguished Service medal. Second Lieutenant Frank Nelms Jr. earned the medal “for extraordinary heroism as a pilot in the First Marine Aviation Force” during several air raids and for his participation in the airdrop of supplies to an isolated French army unit in October 1918. Nelms flew in at an altitude of 100 feet and dropped food under intense rifle and machine-gun fire, not once, but three times.<sup>126</sup> Nelms was commissioned in the Reserve, Class 5, and was among those former U.S. Naval Reserve Force pilots discharged to enter the Reserve to meet the need for pilots in the Day Wing, Northern Bombing Group.<sup>127</sup>

Two reservists earned the Distinguished Service Cross (DSC): Private Sydney G. Gest<sup>128</sup> and Second Lieutenant Fred Thomas. For two separate actions, Thomas earned two DSCs and a Navy Distinguished Service medal. Always in the thick of the action, Thomas also earned four Silver Star citations.<sup>129</sup>

When war was declared in April 1917, the U.S. Marine Corps had less than 14,000 men in active-duty ranks, with another 1,091 Reserve and National Naval Volunteers available for active duty. By mid November 1918, the Marine Corps had more than 75,000 men and women on active duty, and 7,256 were members of the Reserve. While the Reserve represented not quite 10 percent of the Marine Corps at the end of the war, its growth in approximately 17 months was phenomenal.<sup>130</sup>

## Demobilization

Immediately after the Armistice of 11 November 1918 went into effect, demobilization began. The 1st Marine Aviation Force, which returned to the United States in December 1918,<sup>131</sup> disbanded in February 1919, and Marine Flying Field Miami, Florida,

<sup>120</sup> *The Marine Corps Reserve*, 10.

<sup>121</sup> Crosschecked search results of Reserve awards using C. Douglas Sterner, ed., *Marine Corps Heroes, Medal of Honor*, vol. 1 and *Marine Corps Heroes, Navy Cross 1915-WWII*, vol. 2, (Scotts Valley, CA: CreateSpace, 2015); “Preserving the History of Recipients of the Medal of Honor,” *homeofheroes.com*; and Jane Blakeney, *Heroes: U.S. Marine Corps, 1861-1955, Armed Forces Awards Flags* (Washington, DC: Guthrie Lithograph Co. 1957).

<sup>122</sup> Sterner, *Marine Corps Heroes*, vol. 2, 27.

<sup>123</sup> “1st Marine Company, Marine Barracks Philadelphia Navy Yard MRoll, 3 April-30 April 1917,” HIRB, Marine Corps History Division.

<sup>124</sup> Sterner, *Marine Corps Heroes*, vol. 2, 84.

<sup>125</sup> “47th Company, 5th Marine Regiment MRoll, 1 June-30 June 1917” and “rewritten 10 November 1931,” HIRB, Marine Corps History Division

<sup>126</sup> To read the award citation, see “Frank Nelms, Jr.,” Hall of Valor, <http://valor.militarytimes.com/recipient.php?recipientid=16730>.

<sup>127</sup> Reginald Wright Arthur, *Contact! Naval Aviators Careers* (Washington, DC: Naval Aviator Register, 1967), 229.

<sup>128</sup> Blakeney, *Heroes: U.S. Marine Corps, 1861-1955*, 86.

<sup>129</sup> *Ibid.*, 153.

<sup>130</sup> McClellan, *United States Marine Corps in the World War*, 9, 11, 76.

<sup>131</sup> *Ibid.*, 75.



*U.S. Army Signal Corps photograph courtesy of Leatherneck magazine*  
Marines go into the attack in the Meuse-Argonne area, 1918.

closed in September 1919.<sup>132</sup> With the end of the war, the number of Reserve aviators quickly dropped. On 9 September 1918, the Reserve Flying Corps had 11 first lieutenants and 118 second lieutenants. A Marine aviator list published 13 March 1919 reflected just 13 first lieutenants and 60 second lieutenants.<sup>133</sup> The number continued to drop as men transitioned to inactive status or became members of the regular component.

Marines in the brigades were released on a different basis, with individual requests for release

processed as they were received until the new fiscal year began on 1 July 1919. The Naval Appropriations Act approved on 11 July 1919 provided the Marine Corps with funds for an average strength of 27,400 enlisted men plus officers. The pace of demobilization for the brigades then significantly increased. The Marine Corps completed demobilization of the brigades on 13 August. The transfer of reservists on active duty to inactive status was completed on 25 August 1919.<sup>134</sup>

While the World War I Marine reservists returned

<sup>132</sup> LtCol Edward C. Johnson, *Marine Corps Aviation: The Early Years, 1912-1940*, ed., Graham A. Cosmas (Washington, DC: History and Museums Division, Headquarters Marine Corps, 1991), 17.

<sup>133</sup> Headquarters Marine Corps, "A list of Officers of the U.S. Marine Corps and U.S. Reserve on Active Duty Arranged According to Rank," booklet, 9 September 1918; and "A list of Officers of the U.S. Marine Corps and U.S. Reserve on Active Duty Arranged According to Rank," booklet, 13 March 1919, Francis T. Evans, Personal Papers Collection, U.S. Marine Corps Archives and Special Collections, Marine Corps University, Gray Research Center, Quantico, VA.

<sup>134</sup> LtCol Frank E. Evans, "Demobilizing the Brigades," *Marine Corps Gazette* 4, no. 4 (December 1919): 303-4.

to their homes, just as militiamen had done for more than a century, a new and vital source of military capability emerged through the Reserve. Evolutionary changes in American interests, a more international bent, proved the need for a military that could be called upon to do more than “execute the laws of the Union, suppress insurrections, and repel invasions.” The citizen-soldier construct, so important to the

founders of the Republic, was maintained. Although an embryonic force in World War I, the Reserve contributions were significant. It was born at just the right time.

The second, and concluding part, of the special feature on the Reserve in World War I focuses on the birth, growth, and contributions of the Reserve Flying Corps and the Reserve (Female). ♦1775♦

# Development of Medical Doctrine for Amphibious Warfare by the U.S. Navy and Marine Corps, 1920–39

## PART I

Captain Steven L. Oreck, USN (Ret)

### Introduction

The period between the First and Second World Wars saw the development of warfare concepts not previously seen and other concepts that were, at most, still in their infancy at the end of World War I. The notion of amphibious warfare was not new but certainly had not been advanced as a modern technique. The United States Marine Corps led the development of amphibious warfare doctrine and equipment. One piece of the overall doctrine that needed to be established and refined was medical support for amphibious warfare, which was the responsibility of Navy medical staff assigned to support the Marines. As such, a relatively small group of physicians networked to create workable medical support doctrine for amphibious warfare and contributed to the ability of U.S. forces to undertake amphibious operations when America entered World War II.

Medicine and warfare have been bound together for millennia, almost as long as there have been organized militaries and individuals identified as doctors. Hippocrates advised the aspiring *iatros* (physicians/surgeons) that, if they wanted to be surgeons, they should follow the army.<sup>1</sup> The Impe-

rial Roman Army had a well organized and efficient medical service that set standards not exceeded until relatively modern times.<sup>2</sup> While the general principles of military medical care and the organization of a military medical service have remained constant, in many ways, the details of this care must adapt to the circumstances of each campaign. The physical environment, the weapons employed, and the technology of transport are as important as the advances in medical care. As such, amphibious warfare requires that medical doctrine be tailored to fit the unique environment, weapons, and transport vehicles used in this mode of warfare.

Once the Marines had identified a role for which they were particularly suited, and one for which the Army wanted no part, the Corps had to develop the appropriate doctrine.<sup>3</sup> Military doctrine provides a road map for planning and carrying out a set of operations to achieve a given objective. At a minimum, doctrine provides a list of tasks, both planning and operational, that must be accomplished and usually defines who is responsible for those actions. Doctrine gives all of the participants a common starting point and vocabulary, thereby allowing for coordinated planning and execution.

Although amphibious operations have taken place as far back in history as the Persian invasions of Greece, there are no large-scale, successful recent

<sup>1</sup> For more on Hippocrates, see "Who's Who in Greek Medicine: Hippocrates," GreekMedicine, [http://www.greekmedicine.net/whos\\_who/Hippocrates.html](http://www.greekmedicine.net/whos_who/Hippocrates.html).

<sup>2</sup> See "The Military Medicine of Ancient Rome," World History in Context, 2001, <http://ic.galegroup.com/ic/whic/ReferenceDetailsPage/ReferenceDetailsWindow?zid=7a6408a0d3ad1dc47110c6f113b7595b&action=2&catId=&documentId=GALE%7CCV2643450064&source=Bookmark&u=lith7757&jsid=49995908fcd7eeb08c8c7eaa958435ef>.

<sup>3</sup> Kenneth J. Clifford, *Amphibious Warfare: Development in Britain and America from 1920-1940* (Laurens, NY: Edgewood Inc., 1983), 153. In William O. Odom's *After the Trenches: The Transformation of U.S. Army Doctrine, 1918-1939*, which examines in detail U.S. Army doctrinal development in the interwar period, the Army had no discussion or consideration of amphibious warfare until the late 1930s. *Joint Action of the Army and the Navy*, JB-350 (Washington, DC: Joint Army-Navy Board, 1927), 13. Beginning in 1927, the Joint Board that assigned roles and missions for the Services consistently assigned the amphibious assault mission to the Marine Corps.

amphibious assaults to use as a model. The only major amphibious assaults in modern warfare can be seen in the British and French efforts at Gallipoli in 1915 and the smaller German assaults on three Baltic islands in 1917. The latter effort, against an ill-prepared and poorly led force, was successful, while the former against a prepared and well-led force was a disaster.

The primary model for the Marines came from Gallipoli, which was studied extensively as a lesson in what not to do.<sup>4</sup> The German assault on the Baltic Islands in 1917 could also be considered; however, the scale and special circumstances of that campaign, where Russian defenders were, along with the rest of the Russian military, in a partial state of collapse following the revolution, meant the Baltic assault held few lessons for the Marines. A great deal has been written about the development of Marine Corps doctrine for amphibious assaults during the interwar period, and also for the development of key equipment for amphibious warfare, such as the Higgins boat and amphibious tractor (AMTRAC/Alligator).<sup>5</sup> A considerable amount of this development and procurement occurred in spite of, rather than because of, official channels. Warfare is not only about those who pull triggers, the Marines charging across the beach, the big ships providing gunfire support, or the aircraft strafing troops and isolating the beachhead. Take, for example, a well-worn military aphorism that says “amateurs talk tactics, professionals talk logistics.”

One general category of logistics includes medical support, which consists of two main areas: treatment of the wounded and sick; and measures taken to prevent the force from becoming sick (i.e., preventative medicine). Just as other aspects of a military operation must be tailored to the specific circumstances, so too must medical support. Medical support has the same requirement for doctrine as any other aspect of a military operation, and therefore as the Marines developed doctrine for amphibious assault, there was a need for a concomitant medical doctrine for amphibious assault, or more generally all aspects of amphibious warfare, to be developed.

On many levels, line officers tend to give thought to medical support only when it is absent. It was (and often still is) expected that “the docs” would be present when and where needed with the equipment and personnel to provide for the medical requirements of the force.<sup>6</sup> In the case of the Marine Corps, this area of potential miscommunication was exacerbated by the fact that the medical personnel who took care of Marines were all Navy personnel, and they were under the administrative control of the Navy through the Bureau of Medicine and Surgery (BUMED) and the Bureau of Naval Personnel (BUPERS). This could, and frequently did, lend credence to the concept that receiving adequate medical support where and when needed was “the Navy’s problem.” This was certainly the case with the development of amphibious doctrine by the Marines and Navy.

<sup>4</sup> LtCol Kenneth J. Clifford, USMCR, *Progress and Purpose: A Developmental History of the United States Marine Corps, 1900-1970* (Washington, DC: History and Museums Division, Headquarters Marine Corps, 1973), 25; Leo J. Daugherty III, *Pioneers of Amphibious Warfare, 1898-1945: Profiles of Fourteen American Military Strategists* (Jefferson, NC: McFarland & Co., 2009), 204; Tom Fitzpatrick, *A Character that Inspired: Major General Charles D. Barrett, USMC, Amphibious Pioneer* (self-published, 2003), 315; and Gen Holland M. Smith, USMC (Ret), *The Development of Amphibious Tactics in the U.S. Navy* (Washington, DC: History and Museums Division, Headquarters Marine Corps, 1992), 18.

<sup>5</sup> LtCol Merrill L. Bartlett, ed., *Assault from the Sea: Essays on the History of Amphibious Warfare* (Annapolis: Naval Institute Press, 1985); Clifford, *Progress and Purpose*; Clifford, *Amphibious Warfare*; Daugherty, *Pioneers of Amphibious Warfare*; Jeter A. Isley and Philip A. Crowl, *U.S. Marines and Amphibious War: Its Theory and Its Practice in the Pacific* (Princeton: Princeton University Press, 1951); Henry I. Shaw Jr., *Opening Moves: Marines Gear Up for War* (Washington, DC: History and Museums Division, Headquarters Marine Corps, 1991); Gen Holland M. Smith, USMC (Ret), *The Development of Amphibious Tactics in the U.S. Navy* (Washington, DC: History and Museums Division, Headquarters Marine Corps, 1992); Carolyn A. Tyson, *A Chronology of the United States Marine Corps, 1935-1946, Vol II* (Washington, DC: History and Museums Division, Headquarters Marine Corps, 1965) all discuss at length the development of amphibious doctrine by the Marines, and the concomitant search for appropriate equipment, such as landing craft, to carry out its mission. The minutes of the Marine Corps Equipment Board in the late 1930s focus extensively on equipment issues for amphibious warfare both large and small, but only rarely discuss medical equipment. Both the Higgins boat and the amphibious tractor were originally created for civilian use, and were noticed by enterprising Marine officers. The inventors of these craft modified them and made them available at their own expense to the Navy and Marine Corps for evaluation, which resulted in both craft being adopted by the U.S. military.

<sup>6</sup> The distinction between “line” and “staff” (and other nonline officers) varies from Service to Service. In general, staff officers are technical experts such as medical personnel, lawyers, and others. Staff officers are restricted by regulations as to where and how they can exercise authority, as opposed to line officers who are not so restricted. This distinction is important, as staff officers such as doctors advise line officers on medical matters and outside of very technical medical issues, implementation of medical plans and enforcement of medical regulations falls under the purview of line officers.

During the 1920s and the early 1930s, Marines were not researching the issue of medical support, nor was medical support for amphibious warfare being analyzed by BUMED or the Navy line.<sup>7</sup> The Navy emphasized instead building and modernizing the fleet during times of financial stringency and strong pacifistic and isolationist sentiments. At the same time, BUMED worked continually to meet the needs of naval hospitals and ships in the face of personnel shortages. The Marines' needs ranked lower on the priority list, and issues of medical support for potential amphibious operations lower still.

When outlining the basics of amphibious operations and amphibious assaults, medical support in this environment is neither simple nor intuitive. Yet by the time the Corps made its first amphibious assault in August 1942 on Guadalcanal, medical planners had written doctrine for medical support, which the Navy and Marine Corps implemented and which worked. A few months later, when the Army landed in North Africa, they, in conjunction with the Navy, used the same doctrine to support those landings.

Just as with other aspects of amphibious doctrine, that for medical support came as the result of analysis, experimenting, and testing. In fact, a small number of Navy doctors closely associated with the Marines, more or less without direction or sometimes without much support, made it their mission to develop the necessary doctrine. What these doctors did, in fact, had very little to do with direct medical care; their actions were less about better surgical techniques or new medications, and more about devising a system of care adapted to the particular circumstances of amphibious operations. This system encompassed organization, personnel, equipment, and a doctrinal template for planning and implementation that is still the basis for current Marine Corps medical planning.

Doctors with clinical skills and experience were needed to define the parameters of what care, whether preventative or reparative, would be provided to the amphibious task force and assault force. Naval officers with experience in Marine Corps operations were needed to define the parameters of what could be done: in particular, how best to provide the physi-

cal and human infrastructure to produce the desired care within the limits imposed by the realities of an amphibious assault. The process relied on input from specialists; in the end, however, a small group of individuals with disparate skills and knowledge made the hard decisions about overall doctrine and what and who to include on the tables of equipment and personnel.

As a result of their work, appropriate medical doctrine and support was "there" when it was needed; therefore, the military analysts and historians of amphibious warfare who have examined many other aspects of doctrinal development during the interwar period have ignored medical doctrinal developments.<sup>8</sup>

This article represents the first in a three-part series that will explore how the U.S. Navy and Marine Corps established medical doctrine for amphibious warfare during the period between World War I and World War II. In many ways, doctrinal development follows the standard military planning process for any operation: (1) define the mission, (2) produce alternate plans, (3) test these plans (by experimentation or wargaming), (4) repeat these steps until a final plan is promulgated, and (5) finally analyze the plan's success or failure to support the development of future plans. Unlike establishing doctrine and the processes for the development of equipment, creating medical doctrine became almost an informal process. Navy doctors who combined the requisite skills and operated with the Marines saw the need to create this doctrine, and established a casual network of like-minded officers working on the issue.

The use of counterfactuals in history, such as "what if" General Robert E. Lee had won at Gettysburg or the Navy carriers had been docked at Pearl Harbor, are not usually a useful tool. In this case, however, it was valuable to ask the "what if" of amphibious medical doctrine having been thrown together at the last minute. The Gallipoli example answers the "what-if" for our purposes. The section on Gallipoli in the *Official History of the Australian Army Medical Services 1914-1918* (1930) describes in painful detail how the lack of proper planning caused vast amounts of un-

<sup>7</sup> Daugherty, *Pioneers of Amphibious Warfare*, 300-1.

<sup>8</sup> Many of the texts listed have either no reference to medical doctrine development or little mention of medical support for amphibious operations. BUMED histories of World War II discuss medical support for the Marines as it was provided, but essentially nothing about the development of the doctrine/equipment for that support.

necessary suffering. This analysis should also serve as a reminder to those who write military history and to those who study it that military operations work much like an arch, whereby the keystone may be the most important and visible piece but, absent all of the supporting pieces, the arch will collapse no matter how solid the keystone.

## Concepts of Amphibious Warfare

Perhaps no other class of military operations illustrates Clausewitz' maxim that "everything is very simple in war, but the simplest thing is difficult" better than amphibious warfare.<sup>9</sup> Initially, processes appear straightforward and analogous to conventional land warfare, such as loading troops and equipment on transports (in this case ships not trains, wagons, or trucks), deliver them to the point of assault, and once an adequate bridgehead has been secured, the campaign transitions to "normal" land warfare. This superficial analysis, while not inaccurate, is woefully incomplete. Many military analysts would agree that no military operation is as complex as an amphibious assault, no other where attention to detail is as critical, and none more likely to produce large numbers of casualties so quickly.<sup>10</sup>

A basic understanding of the major issues in amphibious warfare is necessary to grasp both the overall process of amphibious warfare doctrine by the Navy and Marine Corps and the corollary issues regarding the development of medical doctrine for amphibious warfare. While the overarching amphibious doctrine and plan provides guidance for the creation of subsections or subplans, medical planners must provide accurate and appropriate input up the chain of command to ensure that their needs are integrated into the overall plan.<sup>11</sup>

An attack that achieves maximum surprise and avoids a direct assault has a higher chance of success, and is much more likely to result in fewer casualties. Unfortunately, amphibious assaults rarely

achieve these conditions. These offensives almost always come from a direct frontal assault, with the force completely exposed during transport to the beach and upon the beach, thus creating the greatest potential for a large numbers of casualties in a short period of time. Unlike a land battle, transporting the wounded to treatment facilities becomes much more difficult. All wounded, even those who could normally walk to an aid station, must be transported back to a ship for the medical care provided on a beach remains limited until it is relatively free from the enemy or incoming fusillades. Once the beach is adequately safe, medical units have to be landed and made operational; such units should be as compact as practicable to conserve weight and space and their resources need to be packed in waterproof containers to prevent spoilage due to spray or submersion.

Ship loading the Amphibious Task Force (ATF) presents a major planning issue in amphibious warfare. Equipment and supplies need to be packed with the requisite units, and placed in storage in the reverse order of use, with equipment needed first on the top. Also, the assault force cannot transport the entirety of one type of equipment (or one class of personnel) in one ship, because if that ship sinks then all is lost. Failure to understand the concepts of combat and spread loading bedeviled American landings at Daiquiri, Cuba, during the Spanish-American War, and the British and Commonwealth troops at Gallipoli. In the former case, vital medical supplies were still onboard ships weeks after the landing due to lack of planning during the loading process. At Gallipoli, medical equipment and supplies were often on different ships than those carrying the medical units, which then landed with only minimal ability to perform their duties. Medical planners must understand what equipment (and personnel) will be needed, when it will be needed, and where it will be needed. Otherwise, appropriate medical care will not be available in a timely fashion.

<sup>9</sup> Carl von Clausewitz, *On War*, ed. Anatol Rapoport (London: Penguin Books, 1982), 164.

<sup>10</sup> Amphibious assaults are almost always direct frontal assaults, the type of attack that generates many casualties in a short period of time. Any medical system (military or civilian) is highly stressed when a large number of casualties arrive in a short period of time potentially overwhelming the system. When the system is limited in personnel and equipment, as in an amphibious assault, and transportation of the wounded is complicated by the need for shore to ship movement, the need for efficient organization including triage, appropriate emergency treatment, and medical regulation is even more important than in other circumstances.

<sup>11</sup> See *Combat Service Support in Amphibious Operations*, MCI 7643 (Washington, DC: Marine Corps Institute, 1988). Medical support is a component of combat service support. See also, *Amphibious Embarkation*, FMFM 4-2 (Quantico, VA: Marine Corps Development and Education Command, 1980) and *Medical and Dental Support*, FMFM 4-5 (Washington, DC: Government Printing Office, 1968).



Until the campaign transitions from an amphibious assault to a traditional land campaign, or an island is secured, transporting wounded involves significant shore-to-ship movement. This is not merely an issue of having adequate landing craft designated for the movement, but also ensuring that the wounded are transported to the appropriate ship with both the facilities and the personnel to receive the wounded but also available space for the wounded. Failure to put such a system (medical regulating) in place was one of many tragedies in the early part of the Gallipoli operation, when barges of wounded drifted from ship to ship trying to find treatment. Even when they found a vessel to off-load the wounded, the receiving ship was frequently inappropriate, lacking appropriate medical spaces, personnel, and equipment.<sup>12</sup>

Some of the equipment issues particular to amphibious operations have been mentioned previously. Simplicity and minimizing the weight and volume of the equipment is important, even more so with amphibious operations than in traditional land campaigns. Equipment must be thoroughly waterproofed or packed in waterproof containers and be protected not just from moisture, but also from highly corrosive salt water. Just as the transports must be combat ready and spread loaded, equal thought and preparation must go to the equipment for a medical unit as this equipment is as liable for loss during the landing as any other.

The many factors specific to amphibious operations illustrate the need for meticulous planning, and for the medical staff to have a concept of operations and doctrine that meshes with that of the command and the operation. The Australian report on Gallipoli, and the results of Army investigations of medical failures from the Spanish-American War, demonstrate the impact of a massive failure of proper medical planning. While medical doctrine for traditional land warfare and assaults can be used as a starting point, the demands of an amphibious assault require a special and specific doctrine.

## The 1920s

The 1920s represent a decade of challenge for the U.S. military, and the Marine Corps was not an exception. Although the United States had become a

major force on the world stage and was more than 20 years into being an imperial power, America was turning inward. The Senate acceptance of the Versailles Treaty with the provisions for the League of Nations was defeated for a variety of reasons, both political and philosophical. The military forces that had been built up for the Great War were rapidly reduced, as Congress and the public saw no need for a permanently expanded force much above prewar levels. Huge stockpiles of everything from uniforms to ammunition sat in warehouses, with the surplus to be used before a parsimonious Congress would consider anything new. In fact, U.S. forces would be eating World War I rations and using all manner of World War I equipment when they went into action after Pearl Harbor.

With massive reductions in funding, carrying out anything more than the most necessary operations was difficult. Money for exercises was slim, and military pay during the 1920s was not competitive with the booming civilian economy. As a result, recruiting was difficult and the Marines were not able to fill even the reduced number of positions they had been allotted. The Navy had personnel shortages as well, which affected the Corps in terms of assigning medical officers and corpsmen to fill full time, as opposed to temporary or exercise only, billets. Operating on even more of a shoestring budget than usual had an effect on plans to revamp Marines as an amphibious assault force. In one respect, the Marines were fortunate. Commandant Lejeune had made the decision about the direction the Corps was going to take, stating formally in 1922: "The primary war mission of the Marine Corps is to supply a mobile force to accompany the Fleet for operations on shore in support of the Fleet. This force should be of such size, organization, armament, and equipment as may be required by the plan of naval operations."<sup>13</sup> Early versions of War Plan Orange (war with Japan) recognized the need to seize island advance bases. Since the Army wanted nothing to do with amphibious warfare, with the amphibious mission formally allotted to the Marines by the Joint Board, the Marines had a well-defined mission to provide a future for an independent Marine Corps even in an era of retrenchment and isolationism. As long as the Ma-

<sup>12</sup> A. G. Butler, *Official History of the Australian Army Medical Services, 1914-1918* (Melbourne: Australian War Memorial, 1938), 115-17.

<sup>13</sup> Clifford, *Progress and Purpose*, 30.

rines could operate within tight fiscal and personnel constraints, developing the amphibious force and its doctrine had been given a green light to proceed.

As noted, Lejeune had taken the Advanced Base Force concept and used it as the springboard for a Marine Corps built around the model of amphibious warfare even before he ascended to the commandancy. Immediately following the end of World War I, Lejeune assigned Major Earl “Pete” Ellis to evaluate potential Marine Corps operations against Japan in the context of an “Orange” war. Following WWI, the chances of a conflict between Great Britain and the United States faded into improbability, and Germany had been eliminated as a threat for the immediate future. The Atlantic Ocean was, so it seemed, secure. However, the Pacific Ocean and Asia still presented the potential for conflict between the United States and Japan. Military planners looked on a U.S.-Japan conflict as the most probable outcome. Civilian and general readership books, such as Walter B. Pitkin’s *Must We Fight Japan?* (1921) and Hector C. Bywater’s *Sea-Power in the Pacific: A Study of the American-Japanese Naval Problem* (1921), highlighted the fact that conflicting American and Japanese interests would lead to war.

Because the German Pacific islands north of the equator had been ceded to Japan under a League of Nations mandate,<sup>14</sup> the sea lanes between Hawaii and the Philippines could be readily interdicted by the Japanese as the U.S. possessions along this route—Midway, Guam, and Wake islands—were isolated and far from any support. It was clear that any attempts by the United States to relieve or recapture the Philippines would require seizing advance bases on islands currently occupied by Japan. In addition, these bases would be needed to support the fleet as it advanced west in anticipation of the Mahanian (Alfred Thayer Mahan: Influential U.S. Navy admiral, historian, and geostrategist in the late 19th century) clash of battle fleets to take place near Japan. Hence,

the study by Major Ellis was presented in 1921. The provisions of the treaty from the Washington Naval Conference in 1922 where the United States and Japan agreed to forgo fortifying almost all Pacific island bases meant that, in case of conflict, most if not all U.S. possessions west of Hawaii would be overrun, thus increasing the need for a plan to seize new or to retrieve old bases.

Ellis’ *Advance Base Operations in Micronesia* (FMFM 12-46), as detailed and prescient as it was, made no mention of casualties or medical treatment of casualties.<sup>15</sup> He would not be the first Marine Corps planner to ignore this issue; most Marine officers saw the issue of medical care as “the Navy’s problem” and, furthermore, felt out of their depth when considering medical issues. This is not to say that the issue of casualties was completely ignored in the war planning process. Captain D. N. Carpenter, Medical Corps, USN, who was a medical planner, outlined the needs for hospital beds in an Orange (Japan) war scenario to Captain H. R. Stanford Civil Engineering Corps, USN, who was a civil engineering officer. Hospital bed needs were estimated at 19,262, however, Carpenter noted that hospitalization (initially) for the Advanced Base Force would be on class A hospital ships, but no estimate was given for the number of ships required.<sup>16</sup>

Fortunately, there were Navy and Marine officers who were aware of the gap between the doctrine of the new Marine Corps and the medical establishment and the doctrine that would support it. Between July 1922 and January 1923, Major S. N. Raynor, USMC, published a six-part series in the *United States Naval Medical Bulletin* entitled “The Functions and Organization of Medical Corps Units Serving with the Marine Corps in the Field.”<sup>17</sup> The editors explained the rationale behind this series of articles in the introduction to the first part:

The writer has undertaken to prepare for the  
UNITED STATES NAVAL MEDICAL BULLE-

<sup>14</sup> Includes the Carolines, Marshalls, and Marianas islands. See George H. Blakeslee, “Japan’s New Island Possessions in the Pacific: History and Present Status,” *Journal of International Relations* 12, no. 2 (1921): 173-91.

<sup>15</sup> Maj E. H. Ellis, *Advance Base Operations in Micronesia*, FMFM 12-46 (Washington, DC: Headquarters Marine Corps, 1921).

<sup>16</sup> Capt D. N. Carpenter, USN, “Memorandum to Captain H. R. Stanford, CEC, USN: estimate of total number of beds required by the medical department for an orange war [SECRET],” 14 November 1924, Record Group 52, National Archives, Washington, DC. Class A hospital ships were fully equipped as floating hospitals and a full medical complement, as opposed to class B ships, which were for transport of the wounded, but had limited treatment facilities. This estimate would include only those beds needed for the treatment of Navy and Marine Corps casualties. Unfortunately, this early estimate of hospitalization needs for these two Services was a gross underestimation.

<sup>17</sup> Maj S. N. Raynor, USMC, “The Functions and Organization of Medical Corps Units Serving with the Marine Corps in the Field,” *United States Naval Medical Bulletin* 17, no. 7 (1922): 220-30.

TIN a series of articles dealing with the functions and suggested organization of Medical Corps units serving with the Marine Corps in the field. Up to the present time there has been no special organization for that service. If the necessity for such special organization can be demonstrated, the quo animo of this series shall have been attained.<sup>18</sup>

Furthermore, the editors informed the readers that Major Raynor had created an appropriate correspondence course through the Marine Corps schools at Quantico, Virginia, and the surgeon general was “desirous” that all medical officers available for service with the Marines take this course.<sup>19</sup> Since a brief article had appeared in this same journal at the beginning of 1922 announcing this course and explaining the rationale behind it, the emphasis and strong endorsement implies that the number of medical officers taking the course must have been below expectations and goals.<sup>20</sup>

At the beginning of part two of this series, the editors elaborated further upon the reasoning behind the series. They detailed how service ashore with the Marines created a different environment with different challenges than working aboard ship or in a hospital and that, to properly function in this setting, the medical officer had to be appropriately trained and educated. This training and education had to include not only the specifics of the duties as a medical officer, but also how to function personally and as a staff officer within the military (as opposed to naval) milieu.<sup>21</sup>

In the article, Major Raynor set forth the notional organization of a Marine brigade with its components, both medical and line.<sup>22</sup> This organization was essentially a copy of an Army unit. Likewise, the notional table of equipment (T/E) that Major Raynor

described was also a copy of the Army T/E. Outlines of the requirements of the administrative order (operations order or “OPORD” in today’s vernacular) and examples of how and with whom to interface on the staff to accomplish tasks were also detailed in the article. Overall, this relatively short article—a distillation of the correspondence course—still represented a giant leap forward when compared to the Navy’s *Landing-Force Manual*.<sup>23</sup> The latter is extremely limited when discussing medical issues, and seems suitable only for addressing the conduct of operations with a relatively small number of sailors detached from a ship to form a landing party.

Although Major Raynor and the Navy medical establishment had made a necessary start to developing doctrine for Navy medical support of the Marines, a critical and glaring hole in this doctrine became obvious: there was no mention of amphibious operations. The concepts of the duties of a senior medical staff officer presented in the article, and development of the medical annex to the overall plan and how to prepare it, were applicable to any operation. However, the very specific issues of amphibious assault were completely ignored. And just as operating with the Marines is very different from operating on a ship, so too is the medical task of an amphibious assault different from that of a “standard” land campaign, which had not yet been articulated.

Almost simultaneously with Major Raynor’s article, the *United States Navy Medical Bulletin* published an article by Lieutenant Commander William L. Mann Jr., Medical Corps, USN. A highly detailed article dealing primarily with the preventive medicine issues of Marine forces ashore, this piece was intended to serve as a “how-to” guide, rather than as a conceptual leap.<sup>24</sup> As with Major Raynor, Lieutenant Commander Mann was dealing with an established

<sup>18</sup> *Ibid.*, 59.

<sup>19</sup> *Ibid.*

<sup>20</sup> “On a Correspondence Course for Naval Medical Officers,” *United States Naval Medical Bulletin* 16, no. 1 (January 1922): 44–46. It is worth noting that, in the comments of part one of the article, the maps needed for the correspondence course are described as being free from a government source. However, in the comments of part two, those who wanted to take the course are told where to get (and pay for) the maps. No doubt the decision to make participants purchase their own maps was made in line with the general parsimony concerning military expenditures in the 1920s.

<sup>21</sup> Raynor, “The Functions and Organization of Medical Corps Units Serving with the Marine Corps in the Field,” 220.

<sup>22</sup> At this time, the brigade was the largest unit in the Marine Corps, and is a subset of a division. As described by Raynor, the brigade consisted of the headquarters elements and two infantry regiments (with attachments) of roughly 3,100 men each. Thus a brigade included approximately 6,500 men.

<sup>23</sup> *Landing-Force Manual*, U.S. Navy (Washington, DC: Navy Department, 1920).

<sup>24</sup> LCdr William L. Mann, USN, “Some of the Functions of the Naval Personnel Serving in the Field, with Special Reference to Field Sanitary Measures,” *United States Naval Medical Bulletin* 19, no. 6 (December 1923): 735–813.

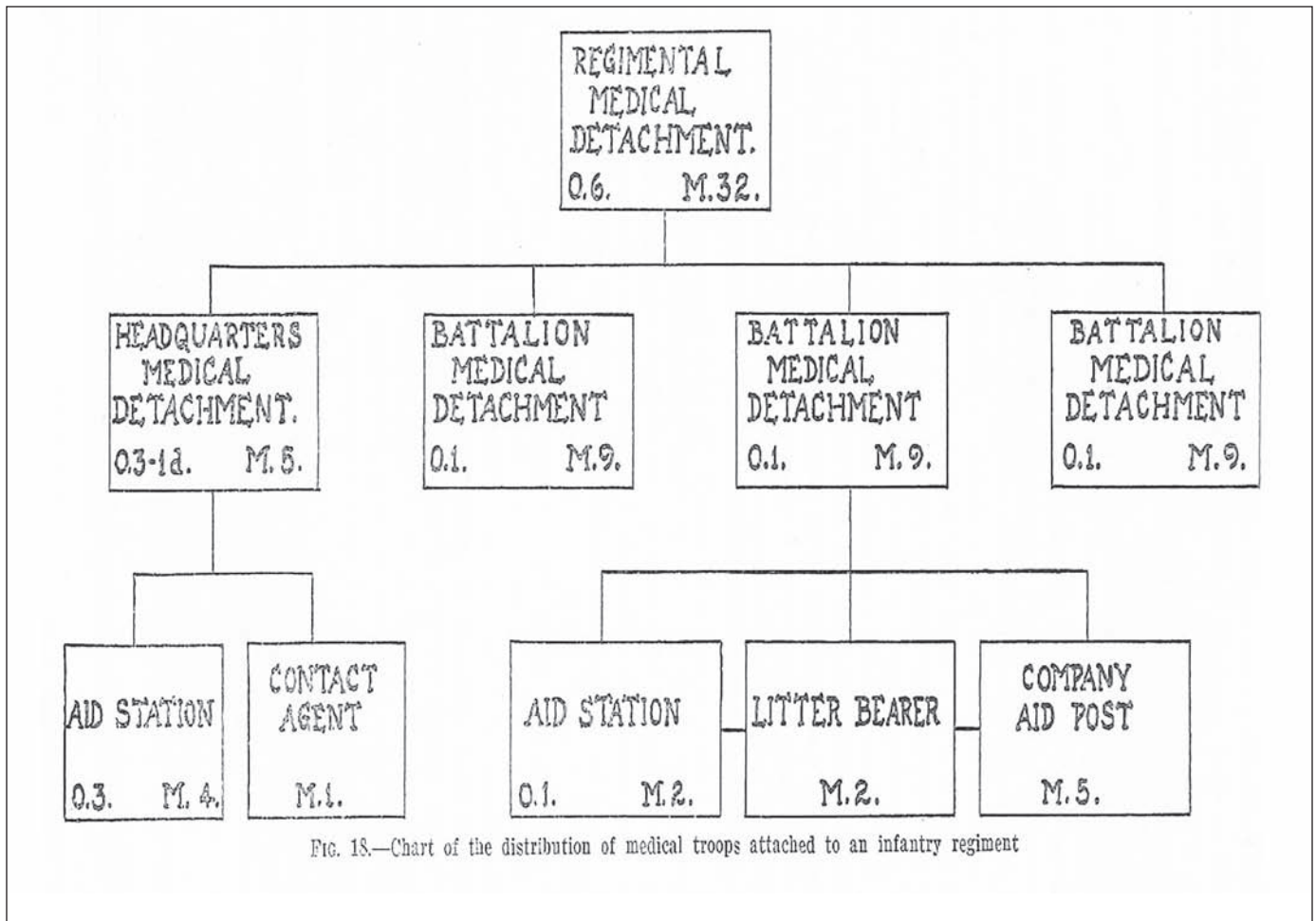

FIG. 18.—Chart of the distribution of medical troops attached to an infantry regiment

Adapted from LCdr William L. Mann, USN, *Medical Tactics in Naval Warfare*  
Medical plan for Marine infantry regiment

land campaign, and issues concerning amphibious assault were not mentioned at all. Similarly, Mann based his organization and planning on Army models. It would not be until 1927 that the Navy would collect and expand upon the articles and publish this compendium as a textbook. Even if many of the concepts and diagrams were essentially copied from Army manuals, his illustrations as well as his text provide the most useful practical guide for a medical officer assigned to the Marines produced to date (see figures 1-4).

These attempts to define medical support for the Marines in the early 1920s should be read in the context of the overall movement to transform the Marines and develop amphibious capability. Study of the British and Commonwealth assault on Gallipoli was considered essential to devising a workable

doctrine for amphibious assault. Brigadier General Robert H. Dunlap, later Commandant of the Marine Corps, noted in his study of Gallipoli published in 1921, that pretty much everything had gone wrong.<sup>25</sup> One of the five major areas that Brigadier General Dunlap highlighted as a failure was evacuation of the wounded, which had been a complete disaster. He noted specifically "evacuation of the wounded, requiring close cooperation between the Army and the Navy" was not performed properly.<sup>26</sup>

The Navy was also giving some consideration to the concepts of amphibious warfare, however, most of the Navy assumed that the Army would be involved in these operations, not the Marines. In a series of articles published in the U.S. Naval Institute *Proceedings* in 1924 and 1925 on Joint Army and Navy operations, Captain William S. Pye, USN,

<sup>25</sup> Fitzpatrick, *A Character that Inspired*, 315.

<sup>26</sup> Daugherty, *Pioneers of Amphibious Warfare*, 206.

# ORGANIZATION OF THE MEDICAL BATTALION.

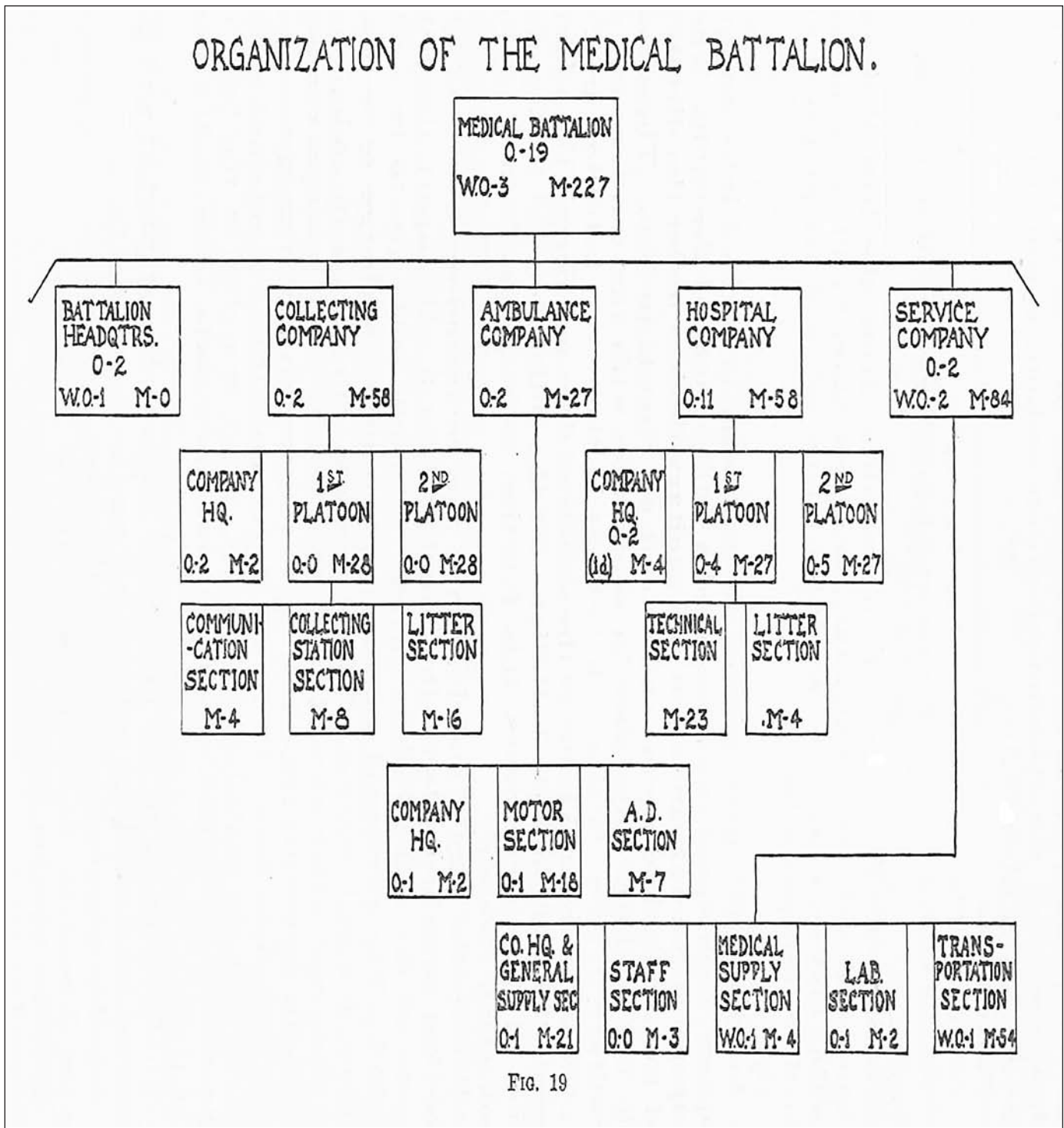
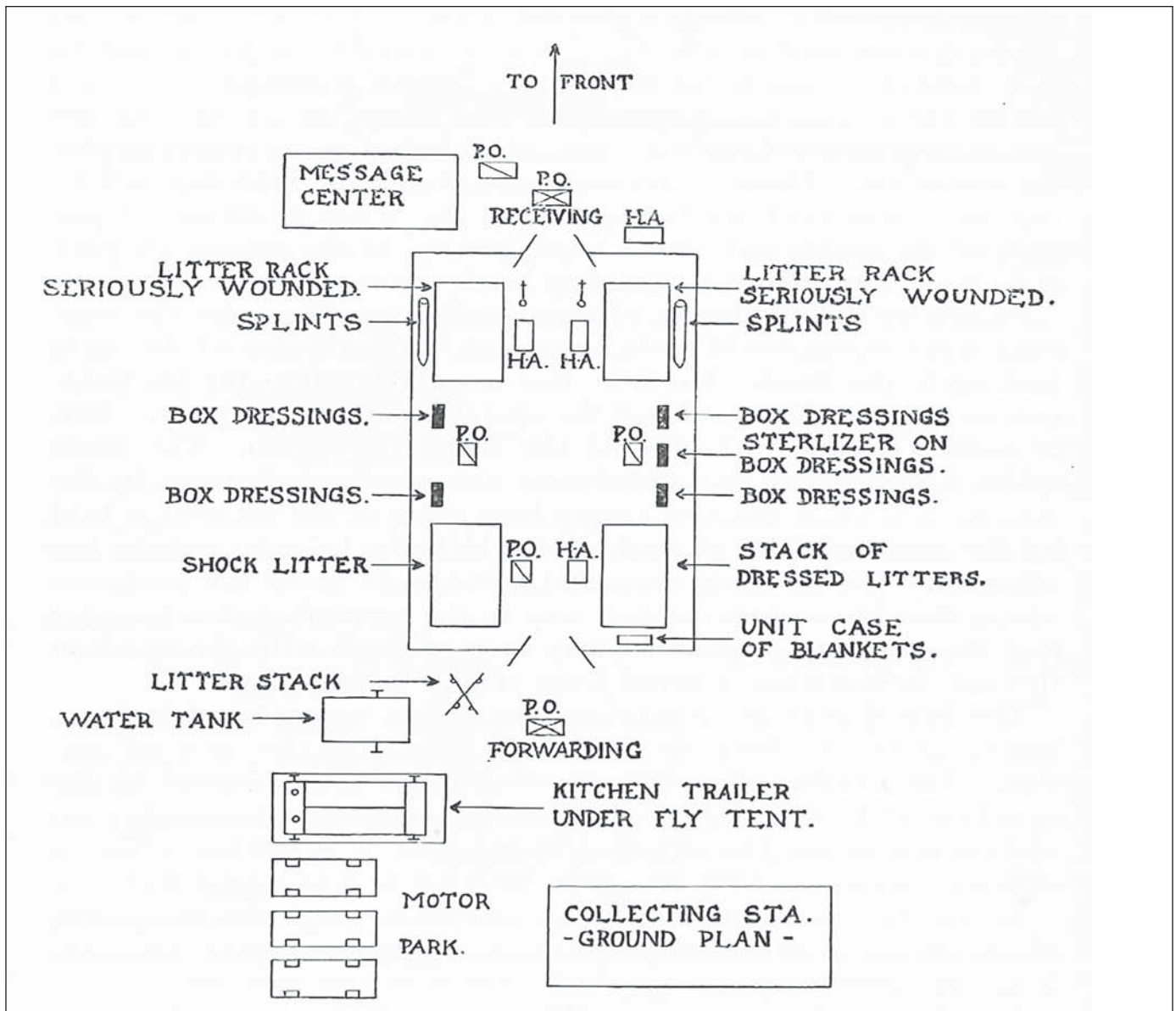

FIG. 19

Adapted from LCdr William L. Mann, USN, *Medical Tactics in Naval Warfare*

considered a wide range of issues. While the articles contained a great deal of detail on such subjects as properly fitting out of troop transports and conversion from standard merchant shipping, certain broad ideas applicable to development of a workable amphibious warfare doctrine were highlighted. These applied not only to overall conduct of amphib-

ious operations, but also applied in terms of medical doctrine as well. Like General Dunlap, Captain Pye drew freely on the experience from Gallipoli and, in the first of his articles, he came out strongly in favor of prewar planning and practice between the Navy and the land component stating: "The British Army and Navy have been conducting joint operations for



Adapted from LCdr William L. Mann, USN, *Medical Tactics in Naval Warfare*

centuries yet the history of the Dardanelles Campaign, their latest large joint operation, indicates that almost every known error was committed at some time during the campaign.<sup>27</sup>

Another lesson from Gallipoli that Pye highlighted was the need for unity of command, and he cited many examples (mostly from British experience) where the lack thereof led to disaster.<sup>28</sup> Unity of command was not present in the medical aspects of the Gallipoli operation as well, where lack of a formal cooperative command structure resulted in ma-

major problems in both planning for and execution of medical treatment and casualty evacuation. In terms of the actual amphibious landing or assault, Captain Pye came to the conclusion that the process of landing troops still needed to be worked out.<sup>29</sup>

In an attempt to understand the workings of an amphibious assault, the Navy and Marines staged several landing exercises in 1922, 1923, and 1924 around the Caribbean at Culebra, Puerto Rico, and the Panama Canal Zone. The 1923 exercise was the first to include a medical component, although it

<sup>27</sup> Capt W. S. Pye, USN, "Joint Army and Navy Operations-Part I," U.S. Naval Institute *Proceedings* 50, no. 12 (December 1924): 1964.

<sup>28</sup> Capt W. S. Pye, USN, "Joint Army and Navy Operations-Part II," U.S. Naval Institute *Proceedings* 51, No. 1 (January 1925): 1-14.

<sup>29</sup> Capt W. S. Pye, USN, "Joint Army and Navy Operations-Part V," U.S. Naval Institute *Proceedings* 51, No. 4 (April 1925): 594.

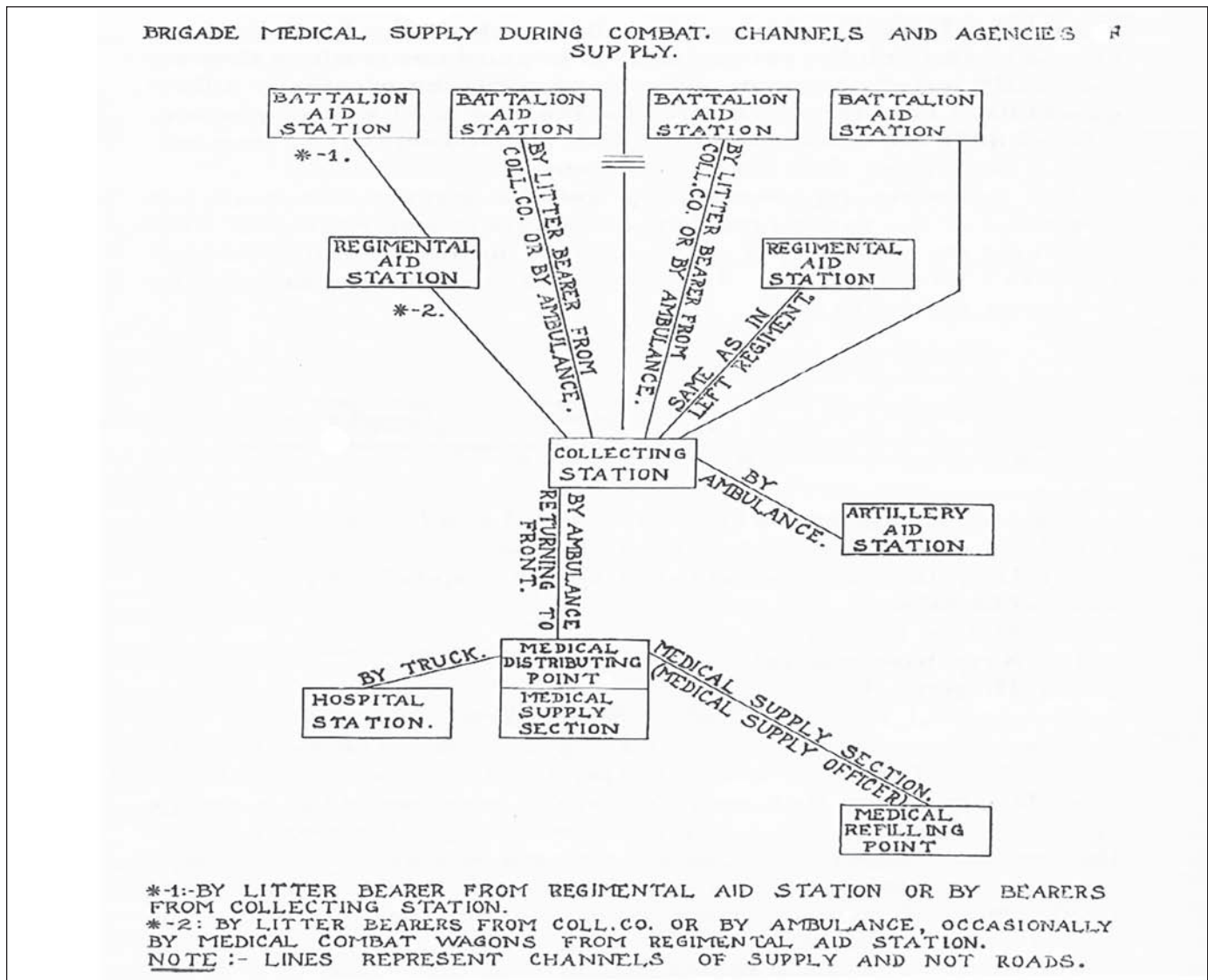

Adapted from Cdr William L. Mann, USN, *Medical Tactics in Naval Warfare*  
 Brigade medical supply system

was small. An aid station (of sorts) was established during the exercise, but it did not include casualty treatment. A more ambitious exercise was held by the Services in Hawaii in 1925.<sup>30</sup> Not surprisingly, these exercises highlighted many shortcomings. The landing force was transported by the Navy on various warships from battleships to destroyers, which made shipboard conditions difficult for the Marines and created significant issues connecting troops with appropriate materiel. While the actual process of getting the Marines ashore improved from the complete shambles it was in 1922, all parties agreed that the use of standard crafts to land troops and supplies

and to evacuate wounded from the beach was inadequate at best. Command and control of all sections represented another area of difficulty.

Unfortunately, the exercises in Hawaii in 1925 were to be the last of the 1920s. Commitments around the Caribbean and in China placed severe fiscal and personnel constraints on the Marines and on the medical personnel assigned to support them. There were neither the personnel nor the dollars available to devote to practicing amphibious landings or to individuals spending a great deal of "official" time working on solutions to the many problems highlighted during these exercises.

<sup>30</sup> Daugherty, *Pioneers of Amphibious Warfare*, 186; Clifford, *Progress and Purpose*, 24-26; and Isley and Crowl, *The U.S. Marines and Amphibious War*, 31-32.



U.S. Navy photo

Medical personnel set up an aid tent on San Clemente Island, California, during casualty movement training in the winter of 1937.

The Bureau of Medicine and Surgery, although very focused on the medical care of sailors ashore and aboard ship and various Navy operational issues, had not completely ignored the issues and needs of the Marines. The annual surgeon general's reports to the secretary of the Navy for fiscal years 1924 and 1925 specifically mentioned, albeit briefly, medical operations with the Marines. In 1924, a report by Lieutenant Commander W. Chambers, Medical Corps, USN, on new equipment for use with the Marines was cited; and in 1925, the report stated "Considerable attention has been given to field service," and the composition (personnel and equipment) of the medical battalion is described in detail, as were the courses of instruction at the schools at Quantico and the naval medical school for field service.<sup>31</sup>

While concentrated efforts in developing doctrine and techniques for amphibious operations were on a hiatus during the second half of the 1920s, some important developments took place. In 1927, the Joint

Board of the Army and Navy formally gave the amphibious warfare mission to the Marines.<sup>32</sup> The Joint Board served many of the same functions as the current Joint Chiefs of Staff does, one of which was to specify the roles and missions of each Service. The 1927 report defined the function of the Marines as follows:

10 (g) to establish and defend advanced naval bases.

11 (a): For land operations in support of the fleet for the initial seizure and defense of advanced bases and for such auxiliary land operations as are essential to the prosecution of the naval campaign.

VI 8 (b): Marine Forces: Marines organized as landing forces perform the same functions as above stated for the Army, and because of the constant association with naval units will be given special training in the conduct of landing.<sup>33</sup>

This Joint Board decision gave the Marines the

<sup>31</sup> *Annual Report of the Surgeon General, U.S. Navy Chief of the Bureau of Medicine and Surgery to the Secretary of the Navy for the Fiscal Year 1924* (Washington DC: Government Printing Office, 1924), 29; and *Annual Report of the Surgeon General, U.S. Navy Chief of the Bureau of Medicine and Surgery to the Secretary of the Navy for the Fiscal Year 1926* (Washington DC: Government Printing Office, 1926), 8.

<sup>32</sup> Craig C. Felker, *Testing American Sea Power: U.S. Navy Strategic Exercises, 1923-1940* (College Station: Texas A&M University Press, 2013), 101.

<sup>33</sup> *Joint Action of the Army and the Navy, 1927, FTP-155* (Historical Amphibious File, General Alfred M. Gray Archive, Marine Corps University, Marine Corps Base Quantico, VA), 3, 13.



green light to recast themselves as they had hoped to, including tasks they were to pursue vigorously once personnel and money became available.

Also in 1927, the Navy published *Medical Tactics in Naval Warfare*.<sup>34</sup> This publication greatly expanded on the series of articles that Commander Mann had published the year prior in the *United States Naval Medical Bulletin*. The sections pertaining to medical support of amphibious operations and the Marines ashore represented the state-of-the-art concepts not only for U.S. forces but also for amphibious medicine around the world. While Mann's article was as complete as anything in 1927, he recognized the limitations of the doctrine as it existed.

The first book on the tactics of landing operations has yet to be written . . . medical tactics connected with this type of military activity must conform and harmonize with the ideas of combatant branches . . . we have been compelled to follow closely, in the preparation of this study, the views outlined to us in informal conversations and discussions with the officers of the Army and Navy who have devoted considerable thought to landing tactics.<sup>35</sup>

Commander Mann had explained the need for Marine specific doctrine, training, and equipment, as distinct from the Army techniques, as follows:

The Naval Medical Department serving with the United States Marine Corps can pattern after and approach the Army medical organization and system of supplies, but unless the mission of the United States Marine Corps becomes identical with the mission of the United States Army, a difference in their two medical services must exist.<sup>36</sup>

In these two statements, Mann summarized the essence of the problems that faced naval medical officers in the coming years. First, that the organization and system (doctrine) for medical support of the Marine Corps must fit precisely with its mission, and secondly that, as of yet, the details of landing

operation missions had not yet been defined. Thus, while lessons of the past could be studied to avoid making the same mistakes, and theoretical work could outline the "what" of medical amphibious doctrine, without well-developed tactics the medical department could make little progress in the "how" of medical doctrine.

Commander Mann then proceeded to present many of the issues that medical planners needed to tackle. He defined four types of Marine Corps operations that required medical support: naval landing parties, organized modern warfare, expeditionary service against semiorganized resistance, and occupation duty against semiorganized resistance.<sup>37</sup> He outlined the different types of medical support for each type of operation, and the specifics of supply for each type of unit.<sup>38</sup>

Mann stressed the need for proper planning for medical aspects of an amphibious operation, particularly for the medical staff to constantly interface with line staff so as to be informed of important tactical considerations and casualty estimates. Like many other Navy and Marine Corps thinkers and planners Commander Mann used Gallipoli and the failures of coordinated planning there to illustrate his point. He also used a quote from Clausewitz' *On War* that is almost a holy writ among planners: "In war everything must be simple, but the simple is usually difficult." It is the natural tendency of the physician to concentrate on the sick or wounded patient in front of them, but the military medical planner has to raise their gaze beyond the individual patient. Because even the most junior doctor assigned to a Marine unit, the battalion surgeon, is by necessity a medical planner, Mann advised that ". . . in the field the distribution of medical supplies, prompt evacuation, skilled first aid, shelter, food, and restoratives available early for every fallen combatant are of infinitely more importance than highly technical relief to difficult cases."<sup>39</sup>

Although unable to get into details for reasons already discussed, Mann did make important points with respect to concepts that had been disastrous

<sup>34</sup> Cdr William L. Mann, USN, *Medical Tactics in Naval Warfare* (Washington, DC: Government Printing Office, 1927).

<sup>35</sup> *Ibid.*, section IIIb, 6.

<sup>36</sup> *Ibid.*, section IIIa, 104.

<sup>37</sup> *Ibid.*

<sup>38</sup> *Ibid.*, section IIIa, 105, 114-45.

<sup>39</sup> *Ibid.*, section IIIa, 102. The importance of this statement of medical priorities cannot be overemphasized.



U.S. Navy photo

During casualty movement training (1937), stokes litters are shown transporting casualties.

at Gallipoli and problematic during the fleet landing exercises of the early 1920s, including medical regulation and loading supplies. He stressed that the medical team required adequate communications to keep track of the wounded and ensure that wounded would be sent to the appropriate locations.<sup>40</sup> Anticipating the conclusions of the Marines who would deal with logistic and supply issues in the next decade, Commander Mann advocated collocating supplies for the medical unit on the same ship that carried medical personnel and ensuring that the most urgent medical supplies were loaded on top so they could be unloaded early in the assault.

Concepts such as combat loading and a proper system of medical regulation, as well as interfacing medical planners with line planners, might seem obvious in hindsight, but as Gallipoli and some of the difficulties in the fleet exercises of the 1920s illustrate, they were certainly not obvious, at least to those making decisions at the time. Although the successful German assault on the Baltic islands of Ösel, Moon, and Dagö was not studied until the early

1930s by American military analysts, it is worth noting that even with the lessons of Gallipoli to guide them, the Germans did not land any medical troops until 48 hours into the assault due to the low priority given them in loading and unloading. Because of the demoralized and disorganized conditions in the Russian Army on those islands and the rapid disintegration of most resistance, the German forces had very few casualties and thus avoided a disaster that might have been caused by poor medical planning.<sup>41</sup>

In addition to the more limited forces involved in direct Marine support, Commander Mann also discussed more capable but forward facilities. During the early part of a campaign, the plan was that hospital ships provided the most capable facilities (class A hospital ships). As the campaign advanced and a significant secure area acquired, tent-based “base hospitals” of 500 beds, expandable to 1,000 beds, were to be established.<sup>42</sup> Other sections of Mann’s book dealt with specific shipboard issues, and sanitation and other measures that would fall under the general heading of preventative medicine.

<sup>40</sup> Ibid., section IIIb, 14. During the amphibious assault phase of the Gallipoli operation, there was no system of medical regulation and boats and barges of wounded were loaded haphazardly. There was an inadequate number of hospital ships and, if they were not available due to location or being at capacity, the wounded were literally brought from ship to ship until one would accept them. This resulted in many wounded being brought onboard ships that had inadequate or even no facilities or personnel to treat them. Preventing this situation is one of the main purposes of a system of medical regulation.

<sup>41</sup> Fred M. Green and C. T. Lanham, “The Invasion and Capture of the Baltic Islands,” *Infantry Journal*, vol. 43 (September-October 1936): 429.

<sup>42</sup> Mann, *Medical Tactics in Naval Warfare*, section II, 3, 23, and section II, 82.

As the 1920s drew to a close, much had been accomplished by amphibious planners, but much was yet to be done. Not only had the Marines decided to transform and become centered around amphibious operations, but the 1927 Joint Board decision had ratified that decision and awarded the Marines that niche within the U.S. military establishment. From the medical side, such pioneers as Commander Mann had already begun serious analysis of the difficulties of medical support for amphibious operations, and had outlined many of the major concerns and had begun to take steps to find solutions. However, absent an overall doctrine for amphibious operations, as well as technical solutions to such problems as adequate landing craft, medical planners could only go so far in their doctrinal designs. Navy and Marine Corps resources were stretched too thin by operational commitments to continue the fleet landing exercises into the second half of the 1920s, robbing the forces of the opportunity to experiment and gain experience.

Most importantly, a small group of naval medical officers led by Commander Mann and Lieutenant Commander W. A. Vogelsang had made an important start. They had properly identified that medical support for amphibious operations was not the same

as medical support for a more “normal” land campaign. Having identified that there was a problem, and a huge gap in doctrine, they had begun to define the individual elements that made up the whole. In fact, the base laid down in the 1920s for defining the outlines of medical doctrine for amphibious operations proved remarkably prescient. Fortunately for Marines, Commander Mann, Lieutenant Commander Vogelsang, Captain Chambers, and others continued to be involved in the development of medical doctrine for amphibious operations.

The close of the decade would usher in both challenges and opportunities for the Marine Corps and the Navy physicians who supported them. The Great Depression would only add to the financial stringencies that all of the armed Services struggled with. At the same time, the marked reduction in overseas commitments of the Marines in the Caribbean and Central America would free up resources for other purposes. As you will see in part two of this discussion, the early 1930s would see an emphasis on the development of Marine Corps doctrine for amphibious warfare, the search for adequate landing craft, and the realization by a small group of Navy physicians of the need for the development of a scheme of medical support to complement this doctrine. ♦ 1775 ♦

# The Importance of Professionalism:

## AN ANALYSIS OF THE 1ST MARINE DIVISION PLANNING PROCESS FOR THE AMPHIBIOUS ASSAULT ON INCHON

Lieutenant Colonel Michael Bonura, U.S. Army;  
Major Michael Padilla, U.S. Air Force;  
Major Kwan Seop Lee, Republic of Korea Army

On 15 September 1950, the commander in chief of U.S. Far East Command (CinCFE), Army General Douglas MacArthur, ordered an amphibious assault at Inchon, which turned the tide of the Korean War. MacArthur envisioned using an amphibious landing to strategically envelope the North Korean advance in the first weeks of the war. Based on his experience commanding amphibious assaults in the Pacific Theater of World War II, he knew the strategic maneuver would require the experience and capabilities of a U.S. Marine Corps division.<sup>1</sup> However, at that time, the only Marine division available was the partially mobilized 1st Marine Division under Major General Oliver P. Smith.<sup>2</sup> Because of the requirements of the mobilization, the entire planning effort for the landing forces fell on a small portion of the 1st Marine Division staff that at the time was forward deployed to Japan ahead of the rest of the division. These hard-pressed staff officers planned the difficult amphibious assault in less than two weeks, issuing to the dispersed units of the division a detailed operations and administrative order that set the stage for the successful landing.

The 1st Marine Division staff officers who planned

the Inchon landing were as competent as MacArthur knew they would be, but the assault planning took more than competence to complete. The staff officers coordinated the efforts of supporting U.S. Army and Navy headquarters into a single team that increased their effectiveness and provided the extra effort needed to plan the Inchon landing. Joint Publication 1 states that competence and teamwork are considered elements of professionalism.<sup>3</sup> The actions of individual staff officers, and the 1st Marine Division Staff as a whole, demonstrated a commitment to these elements of professionalism. This professionalism played a key role in distributing a detailed plan to the 1st Marine Division in time for the Inchon landing. For the 1st Marine Division Staff, professionalism was a vitally important component of the planning process.

### Undertaking The Inchon Landing on a Short Timeline

Almost from the beginning of the Korean War, MacArthur envisioned using an amphibious assault to envelop the North Korean advance and cut their lines of communication thus relieving pressure on the Pusan perimeter. In the first week of July 1950, MacArthur created the Joint Strategic Plans and Operations Group led by General Edwin K. Wright to plan a landing in the Seoul area named Operation

<sup>1</sup> William Manchester, *American Caesar: Douglas MacArthur 1880-1964* (New York: Little, Brown and Company, 1978), 277-375.

<sup>2</sup> Gail B. Shisler, *For Country and Corps: The Life of General Oliver P. Smith* (Annapolis, MD: Naval Institute Press, 2009); and Clifton LA Bree, *The Gentle Warrior: General Oliver Prince Smith, USMC* (Kent, OH: Kent State University Press, 2001).

<sup>3</sup> Office of the Joint Chiefs of Staff, *Doctrine for the Armed Forces of the United States*, JP-1 (Washington DC: U.S. Government Printing Office, 2013), B-1, B-3.

Bluehearts.<sup>4</sup> As part of the initial planning for Operation Bluehearts, MacArthur tasked the Amphibious Group I (PhibGruOne) staff to undertake a study of Inchon as a potential landing site. Led by the experienced amphibious assault commander Navy Rear Admiral James H. Doyle, PhibGruOne consisted of the amphibious command ship USS *Mount McKinley* (AGC 7), an attack transport ship, and an attack cargo ship. Doyle's group arrived in Japan just before the start of the Korean War to conduct amphibious exercises, and the staff was immediately available to begin the amphibious planning effort.<sup>5</sup> The arrival of Doyle and his task force was one of the most fortuitous coincidences of the war for MacArthur and his dream for a strategic envelopment.

James Doyle was one of the most experienced amphibious assault commanders of the Second World War. After distinguishing himself as the commander of a destroyer in the North Atlantic, Doyle was transferred to the Pacific where he served on the Amphibious Force staff. While on the staff, he earned the Legion of Merit for meritorious service during the Soloman Islands Campaign. In particular, he played especially important roles in the landing and occupation of Guadalcanal and Tulagi. It was during the Soloman Islands Campaign that Doyle earned his reputation for amphibious warfare. In 1948, he took command of the Navy's Amphibious Training Command, Pacific Fleet, and for two years was responsible for the training of all amphibious groups in the Pacific. With experience in command of amphibious operations, on the staff of amphibious operations for the Pacific Fleet, and then as the commander of all amphibious training for the Pacific Fleet, the Navy made Doyle the commander of Amphibious Group One for the Pacific Fleet in January 1950.<sup>6</sup> This was the command that Doyle led to Japan in the weeks before the Korean War.

The PhibGruOne study looked at all the beaches

in the Seoul area that could support a landing. The study became the basis for all subsequent planning for the Inchon landing. However, when MacArthur deployed the divisions allocated for Operation Bluehearts to the Pusan perimeter, he cancelled the planning for Bluehearts. Thus by the end of June, the strategic envelopment by amphibious landing was nothing more than an idea. On 10 July during a conference at Far East Command (FECOM) headquarters, Marine Corps officers assured MacArthur that the 1st Marine Division could be mobilized and ready for amphibious operations by September.<sup>7</sup> That same day, MacArthur sent an official request to the Joint Chiefs of Staff for the use of the 1st Marine Division for an amphibious assault. Subsequently, on 13 July, during an update on the war effort, MacArthur briefed Army Chief of Staff General J. Lawton Collins on the amphibious plans.<sup>8</sup> Collins took MacArthur's preliminary plans to the Joint Chiefs for review. MacArthur required approval from the Joint Chiefs of Staff for an amphibious landing and getting that approval delayed the planning process.

Planning for the amphibious envelopment was abbreviated at every echelon of the process. MacArthur ordered his staff to develop three plans, focused on three different landing areas that threatened Seoul, for what would become Operation Chromite. However, even then, MacArthur favored Inchon as the landing site. The FECOM staff issued these plans as CinCFE Operations Plans 100-B, 100-C, and 100-D on 12 August. It took several high-level meetings of the Joint Chiefs of Staff to come to a consensus and approve an amphibious landing. MacArthur received authorization on 23 August to proceed with the Inchon landing as outlined in Plan 100-B.<sup>9</sup> Due to the complex nature of the tides and the shallow approaches to the Inchon harbor, the landing would only be feasible a few days each month.<sup>10</sup> With a renewed North Korean offensive under way, Mac

<sup>4</sup> Roy E. Appleman, *South to the Naktong, North to the Yalu*, CMH Pub. 20-2-1 (Washington DC: U.S. Army Center of Military History, 1961), 488-89.

<sup>5</sup> James A. Field Jr., *History of United States Naval Operations: Korea* (Washington, DC: U.S. Government Printing Office (GPO), 1962), 46, 53, 171.

<sup>6</sup> U.S. Naval History and Heritage Command, "James Henry Doyle, 29 August 1897-9 February 1981," <http://www.history.navy.mil/research/histories/biographies-list/bios-d/doyle-james-h.html>.

<sup>7</sup> Lynn Montross and Nicholas A. Canzona, *U.S. Marines in Korea 1950-1953: The Inchon-Seoul Operation*, vol. 2 (Washington DC: GPO, 1955), 10-11.

<sup>8</sup> James F. Schnabel, *Policy and Direction: The First Year* (Washington, DC: U.S. Army Center of Military History, 1992), 140-41.

<sup>9</sup> Office of the Joint Chiefs of Staff, *Joint Military Operations Historical Collection* (Washington, DC: GPO, 1997), II-5.

<sup>10</sup> 1st Marine Division, *FMF, Special Action Report Inchon-Seoul 15 September-7 October 1950* (Washington, DC: Marine Corps History Division, 1951), hereafter *1st Marine Division, Special Action Report*, 12, [http://www.koreanwar2.org/kwp2/usmc/001/M001\\_CD01\\_1950\\_09\\_52.pdf](http://www.koreanwar2.org/kwp2/usmc/001/M001_CD01_1950_09_52.pdf).

Arthur ordered Operation Chromite to begin on 15 September 1950.<sup>11</sup>

Army doctrine, during the Korean War, required 160 days from conception to execution for an amphibious landing.<sup>12</sup> From the FECom staff's initial planning date on 10 July to the landing date of 15 September, U.S. forces had only 68 days to execute the plan. FECom used 34 of those days to issue the operations plan that, after 11 days of deliberation, left the 1st Marine Division with only 23 days for planning and preparation for the Inchon landing.

At the tactical level, a published operations order culminates a military planning effort. During the Korean War, Marine doctrine divided the orders process into two parts: an operations order that contained all of the planning devoted to the actual assault and an administrative order that covered all of the logistical requirements to support the operation. On 4 September 1950, the 1st Marine Division issued Operations Order 2-50 and Administrative Order 2-50. Operations Order 2-50 was two pages long and included a succinct description of the missions for each of the units that made up the landing force.<sup>13</sup> The details of the plan were distributed in 84 pages of annexes that included the task organization, an intelligence analysis, an operations overlay, and a landing plan. Operations Order 2-50 also referenced Administrative Order 2-50 for the logistics details of the amphibious landing. Administrative Order 2-50 was nine pages and laid out a complete logistical support plan for the operation.<sup>14</sup> Following the base order, 52 pages of annexes detailed the plans for personnel administration, shore party, medical, engineering, baggage, and beach and port development for the exploitation of Inchon by other American forces. Issuing the order on 4 September provided ample time for distributing the orders to the scattered division elements before sailing to Inchon on 8 September. However, the delay reduced

the planning time for the Inchon landing to twelve days.

Twelve days presented a significant challenge for the 1st Marine Division staff because the mobilization and embarkation of the division limited the staff officers available to plan the landing. At the beginning of the war, 33 staff officers from 1st Marine Division deployed to Korea with the 1st Provisional Marine Brigade to bring the brigade staff to full strength. Additionally, the division had pulled Marines from a mixture of existing formations, security detachments, and recalled reservists to fully man the 1st Marine Division.<sup>15</sup> This mobilization included Reserve units from California and Arizona and Marines from Hawaii, Guam, and units afloat. For example, the Marine Corps activated the 7th Marine Regiment on 17 August 1950, with Marines from the 3d Battalion, 6th Marine Regiment, afloat in the Mediterranean Sea, and Marines from the 1st Marine Division rear echelon and Camp Pendleton, California.<sup>16</sup> Fifty-one staff officers and noncommissioned officers organized and transported the division to Japan. The remaining 23 staff officers became the division's initial planning staff, which arrived in Tokyo, Japan, by air on 19 and 22 August.<sup>17</sup> The short planning timeline for the Inchon landing forced 1st Marine Division staff to focus only on the most critical planning elements required to produce a detailed operations and administrative order. This presents an opportunity to identify the most significant factors that contributed to the Marine's successful planning effort.

## Analyzing the 1st Marine Division Planning Process

It is important to analyze the planning process of the 1st Marine Division staff based on the staff sections used to divide the planning effort for Operation Chromite as opposed to using the staff sections currently being used by the United States Marine Corps.

<sup>11</sup> Appleman, *South to the Naktong*, 488-95.

<sup>12</sup> *Headquarters X Corps: War Diary Summary for Operation Chromite, 15 August-30 September 1950* (Washington, DC: Department of the Army, 1950), 3, <http://cgsc.contentdm.oclc.org/cdm/ref/collection/p4013coll11/id/831>.

<sup>13</sup> *Operation Order 2-50: 1st MarDiv [Rein]* (Washington, DC: Headquarters Marine Corps, 4 September 1950), <http://www.recordsofwar.com/korea/USMC/Box%202-4.pdf>.

<sup>14</sup> All of the annexes were attached to Administrative Order 2-50. *Administrative Order 2-50: 1st MarDiv [Rein]* (Washington, DC, 4 September 1950), 1-9, <http://www.recordsofwar.com/korea/USMC/Box%202-5.pdf>.

<sup>15</sup> Montross and Canzona, *U.S. Marines in Korea 1950-1953*, 17-24, 30-33, 55-56.

<sup>16</sup> *7th Marine Regiment: Historical Diary, August 1950-January 1951* (Washington, DC: Headquarters Marine Corps, 1951), [http://www.koreanwar2.org/kwp2/usmc/083/M083\\_CD22\\_1950\\_08\\_2281.pdf](http://www.koreanwar2.org/kwp2/usmc/083/M083_CD22_1950_08_2281.pdf).

<sup>17</sup> *1st Marine Division, Special Action Report*, 9.

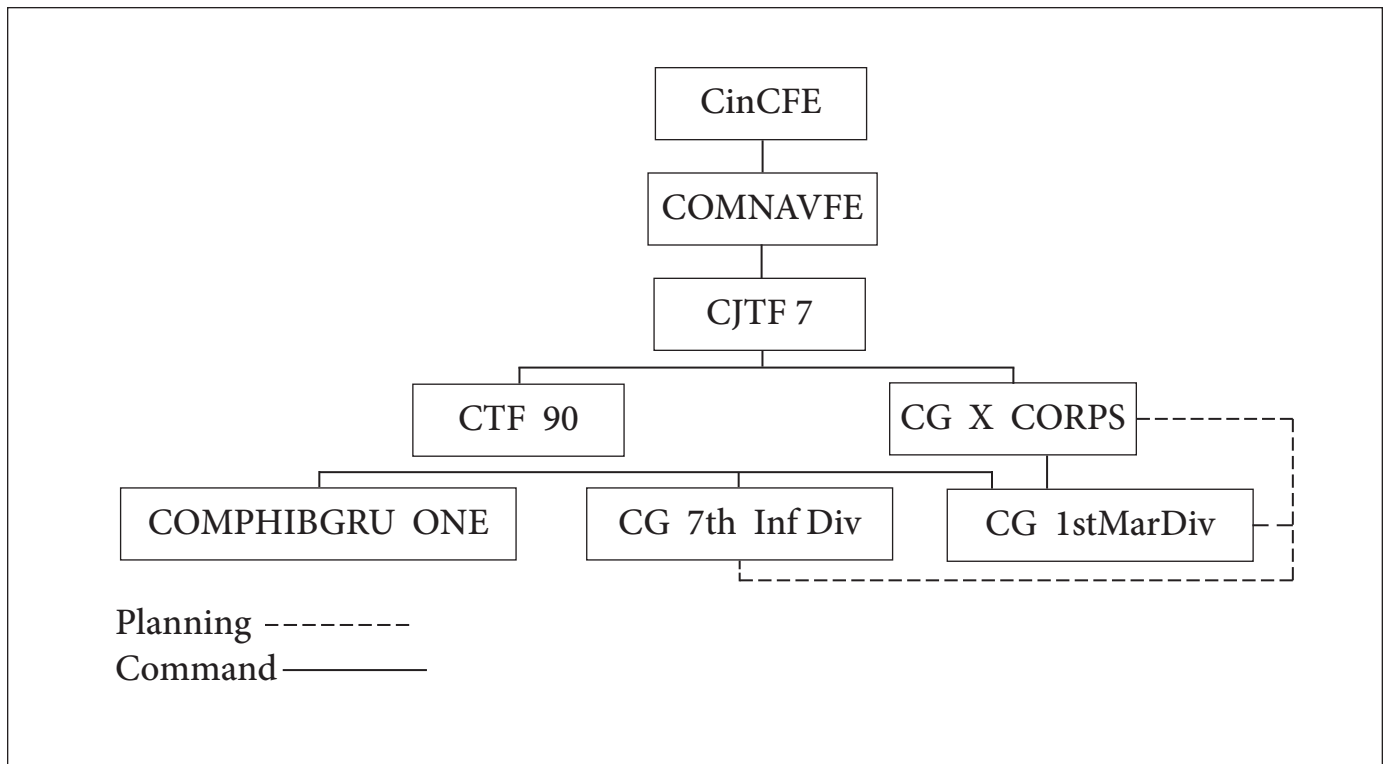

*1st Marine Division, Special Action Report, 9*

Figure 1. This is the diagram of the initial command relationships for the Inchon landing as understood by the 1st Marine Division staff. Note: ComPhibGru One was the designation of the commander, Amphibious Group One or RAdm Doyle.

The 1st Marine Division staff that served throughout the Korean War had nearly the same organization as the Marine divisions that served during World War II. The organization included 26 staff sections, consisting of the adjutant, chaplain, chemical warfare and radiological defense, operations, legal, ordinance, supply, and civil affairs to name a few.<sup>18</sup> Many sections were unrepresented in the small planning staff sent to Tokyo for the Inchon landing. Therefore, to understand the 1st Marine Division planning process, this article will analyze only the command and control relationships created for the Inchon landing and the staff sections of personnel (G-1), intelligence (G-2), operations (G-3), and logistics (G-4). The 1st Marine Division staff produced a special action report detailing the planning, preparation, and execution of Operation Chromite with annexes written by the G-1, G-2, G-3, and G-4 staff sections. Historians often overlook the more mundane and administrative efforts of staff officers, and instead concentrate on the more exciting and interesting actions of com-

bat leaders and troops. The special action report, written by division staff sections and officers, provides a detailed look into the planning process for Operation Chromite that includes not only the challenges the staff faced, but also recommendations for future operations. The report provides a significant amount of information on the division's planning effort from which this analysis is largely drawn.

## The Command Structure for Operation Chromite

The abbreviated planning time line for Operation Chromite created a non-doctrinal and, at times, convoluted command structure for the 1st Marine Division. The command relationships for Operation Chromite followed two different phases: figure 1 represents the initial planning relationships and figure 2 represents the relationships during the landing operation. The figures are reprints from the 1st Marine Division special report and represent the division's understanding of its chain of command.

<sup>18</sup> *1st Marine Division, Special Action Report, 7.*

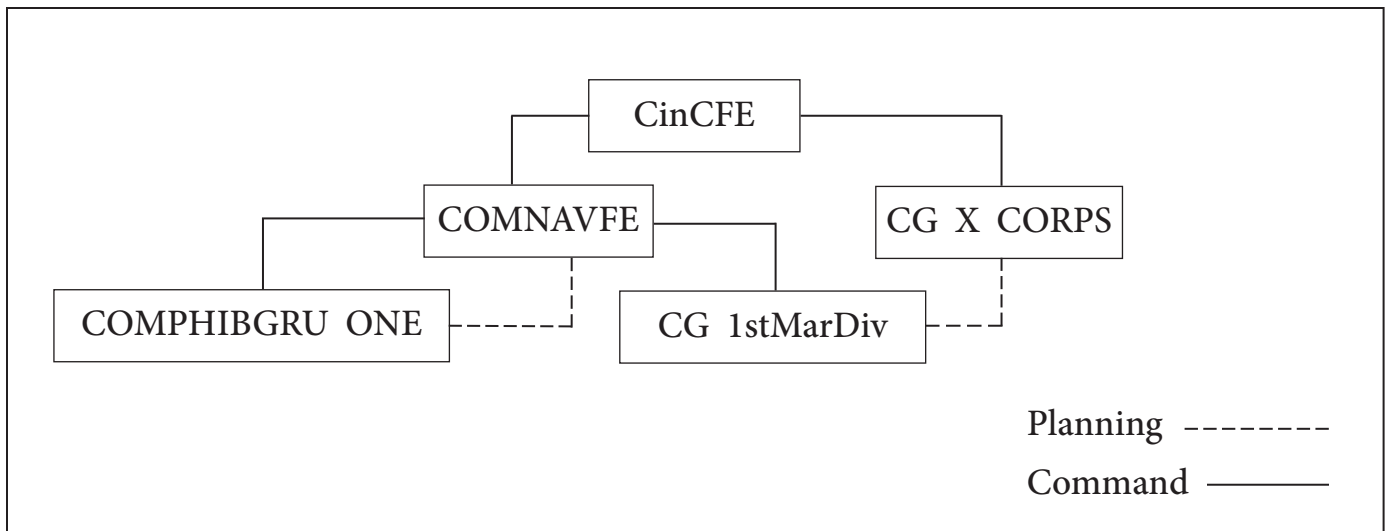

*1st Marine Division, Special Action Report, 10*

Figure 2. This is a diagram of the command relationships during the Inchon landing as understood by the 1st Marine Division staff.

On paper, the command relationships outlined in figures 1 and 2 appear straightforward and in line with the amphibious assault doctrine of both the Army and the Navy going into the Korean War. The Navy's amphibious landing doctrine remained unchanged since World War II. The 1943 document, *Landing Operations Doctrine*, established the attack force, which consisted of the naval task group and the landing force. This attack force usually included the senior naval commander of the naval task group, while the landing force consisted of the Marine or Army units comprising the troops landing on the beach. The landing force commander was usually the senior commander of the service, whether Army or Marine, that contributed the largest number of troops to the landing.<sup>19</sup> The landing doctrine outlined the specific duties and responsibilities of the attack and landing forces in an amphibious operation. While the command relationships seem straightforward, in practice, a great deal of friction existed between the commands in relation to the 1st Marine Division.

The friction was due largely to the piecemeal creation of the headquarters charged with exercising command and control over the entire operation. The headquarters that began the initial planning for Op-

eration Chromite was the PhibGruOne staff, which conducted the initial study of the Inchon harbor. This allowed the PhibGruOne staff to begin planning for the Inchon landing before any other headquarters. However, they were not the headquarters in charge of the entire Inchon landing. The senior naval commander over both PhibGruOne (as the naval task force) and the 1st Marine Division (as the landing force) was the Seventh U.S. Fleet commander, Navy Vice Admiral Arthur D. Struble.<sup>20</sup> In CinCFE Operation Plan 100-B, MacArthur designated the Seventh Fleet as Combined Joint Task Force 7 (CJTTF-7) and made Struble the attack force commander.<sup>21</sup> CJTTF-7 was in charge of the entire Inchon landing operation, but not in the way described in *Landing Operations Doctrine*. Doctrinally, Admiral Doyle should have been the attack force commander as the senior officer of the naval task force, but MacArthur personally gave command of the CJTTF-7 to Admiral Struble. This led to misunderstandings for the 1st Marine Division staff when they received guidance and verbal orders from Admiral Struble.<sup>22</sup> The confusing chain of command was exacerbated by the fact that Admiral Struble arrived in Tokyo on 25 August while the CJTTF-7 staff, onboard the USS *Rochester* (CA 124),

<sup>19</sup> Office of U.S. Naval Operations, Division of Fleet Training, *Landing Operations Doctrine*, F. T. P. 167 (Washington DC: GPO, 1943), 29-33.

<sup>20</sup> U.S. Naval History and Heritage Command, "Arthur Dewey Struble, 28 June 1894-1 May 1983," <http://www.history.navy.mil/research/histories/biographies-list/bios-s/struble-arthur-dewey.html>.

<sup>21</sup> CinCFE Operations Plan 100-B, LtGen Edward M. Almond Papers, RG 38, Box 5, Folder 1, MacArthur Memorial Archives and Library, Norfolk, VA.

<sup>22</sup> *1st Marine Division, Special Action Report*, 11.



was still steaming toward Japan. Therefore, while Admiral Struble gave guidance for the planning process, the CJTF-7 staff did not issue an order before the PhibGruOne and 1st Marine Division staffs began planning their portions of the operation. This led to conflicting guidance from the commanders of CJTF-7 and the naval task force that adversely affected the 1st Marine Division's parallel planning process.

While CJTF-7 was responsible for the entire approach and landing at Inchon, MacArthur wanted a corps headquarters to command the ground attack from Inchon to Seoul, in accordance with the joint operations doctrine between the Army and the Navy from before World War II. The document, *Joint Action of the Army and the Navy*, states that the military Service with paramount interest will be identified for each phase of a joint operation and that the command relationships will be defined for each phase.<sup>23</sup> Therefore, the designation of an Army corps to command the 1st Marine Division ashore complied with the existing doctrine for the execution of joint operations. On 15 August, MacArthur created the U.S. Army X Corps, under the command of Major General Edward M. Almond, to exercise command and control over both the 1st Marine Division and the Army's 7th Infantry Division. MacArthur created the X Corps staff out of the special planning group of the FECom general staff that planned Operation Chromite.<sup>24</sup> This small group of planners led the effort to produce the CinCFE Operations Plans 100-B, 100-C, and 100-D, and benefited from the fact that Almond was also MacArthur's chief of staff. Due to operational security concerns, the headquarters was not activated as X Corps until 26 August when it began issuing directives and orders for Operation Chromite.<sup>25</sup> The activation posed no threat to the unity of command needed to plan a difficult operation on an extremely shortened time line.

The Army entered the Korean War using landing doctrine that closely mirrored *Landing Operations Doctrine*. Although Army officers continued discussing amphibious operations in the years after World War II and compared the way Army and Marine units conducted such landings, no new doctrine for Army amphibious operations existed in 1950.<sup>26</sup> The Army published *Landing Operations on Hostile Shores* in 1941 based on the Navy's existing landing doctrine.<sup>27</sup> The Army went to war in 1950 with essentially the same landing doctrine as the Navy, doctrine that was familiar to the officers of the 1st Marine Division. Therefore, the 1st Marine Division staff had no reason to believe that the orders and directives of X Corps prior to the landing would contain unexpected guidance or attempt to direct actions outside the purview of the commander of the operation after the successful landing. However, the 1st Marine Division staff did receive confusing and often conflicting guidance from the X Corps staff.<sup>28</sup> Consequently, the division staff had no clear expectations of what guidance and control to expect from CJTF-7 or X Corps. For example, X Corps Operations Order No. 1, issued on 28 August 1950, identified the 1st Marine Division as the landing force for Operation Chromite and established the task organization for the landing.<sup>29</sup> The task organization was reflected in Annex A of 1st Marine Division Operations Order 2-50.<sup>30</sup> The guidance, however, should have come from the attack force commander, not the commander of the ground operations following the landing. One recommendation from 1st Marine Division staff, included in the *Special Action Report*, was to use command relationships established in the applicable doctrinal publications along with their doctrinal titles to clearly delineate the status and authority afforded to each echelon of the chain of command.<sup>31</sup> From the perspective of the 1st Marine Division staff, the higher headquarters MacArthur

<sup>23</sup> The Joint Board, *Joint Action of the Army and the Navy*, F. T. P. 155 (Washington, DC: GPO, 1936), 1.

<sup>24</sup> *Headquarters X Corps*, 2-3.

<sup>25</sup> Commanding general Operation Chromite, General Order No. 1, 26 August 1950, LtGen Edward M. Almond Papers, RG 38, Box 5, Folder 1, MacArthur Memorial Archives and Library, Norfolk, VA.

<sup>26</sup> Donald W. Boose Jr., *Over the Beach: U.S. Army Amphibious Operations in the Korean War* (Fort Leavenworth, KS: Combat Studies Institute Press, 2008), 65-81.

<sup>27</sup> U.S. Army chief of staff, *Landing Operations on Hostile Shores*, FM 31-5 (Washington, DC: GPO, 1941).

<sup>28</sup> *1st Marine Division, Special Action Report*, 11.

<sup>29</sup> X Corps Operations Order No. 1 as cited in Montross and Canzona, *U.S. Marines in Korea 1950-1953*, 306.

<sup>30</sup> *Operation Order 2-50*.

<sup>31</sup> *1st Marine Division, Special Action Report*, 27.

established for the Inchon landing did not contribute to the success of the operation or to the planning effort for the landing force.

One command relationship vital to 1st Marine Division's success during Operation Chromite was the relationship with the PhibGruOne staff. After arriving in Japan, the division staff collocated with the PhibGruOne staff on the *Mount McKinley*.<sup>32</sup> Conditions onboard the *McKinley* were barely adequate to meet the needs of one operations staff, much less two staffs simultaneously. There was a shortage of desk and work space, reproduction facilities, and even typewriters aboard the *Mount McKinley*.<sup>33</sup> Additionally, 1st Marine Division staff requested significant support from the PhibGruOne staff to cover personnel gaps, including reproduction assistance and clerks.<sup>34</sup> The crew of the *McKinley* supported every request from the 1st Marine Division staff in addition to supporting PhibGruOne. Both staffs had knowledge of and consented to the others planning activities and operational decisions. No rivalries existed between the organizations. And the limited planning resources and short time line served to synergize the efforts of both staffs. Without direction from their respective commanders, the 1st Marine Division and PhibGruOne staffs came together to form a single joint planning team.

In addition to the teamwork that grew between the PhibGruOne staff and the 1st Marine Division planning staff in Tokyo, the doctrinal nature of the staffs' relationship facilitated their cooperative efforts. *Landing Operations Doctrine* detailed the responsibilities and duties of both the attack force and the landing force during amphibious operations. From the start, the 1st Marine Division staff considered Admiral Doyle to be the attack force commander and the PhibGruOne staff to be the attack force staff.<sup>35</sup> Thus, the Marines expected PhibGruOne to organize the naval task force according to doctrine, to be responsible for ship-to-shore communications, and to organize the transportation group to land forces and supplies on the shore. Similarly, the Ma-

rines were responsible for organizing the embarkation groups and landing groups, which corresponded to the transportation division organization of the naval task force.<sup>36</sup> Because both staffs understood their doctrinal responsibilities, their planning efforts were efficient as each staff understood exactly how their efforts fit into planning for the other force. This relationship enabled the Marines to issue Operation Order 2-50 for the Inchon landing in only 12 days, which left enough time to distribute the order before the initial movement to Inchon on 8 September.

## G-1 Personnel Planning Process

The division's prewar operations as well as additional planning staff requirements placed on the G-1 section created several issues for personnel planning. Before the Korean War, the 1st Marine Division had only 30 percent of its authorized strength present for duty.<sup>37</sup> In the undermanned division, personnel operations were primarily administrative in nature, and members of the G-1 section did not participate in field training exercises. This led to a lack of preparedness in the G-1 section for understanding staff requirements for combat. Additionally, personnel operations training was nonexistent at the Marine Corps professional military educational courses, so units had few trained Marines to fulfill normal personnel functions. These included administrative responsibilities such as the processing of pay, promotion, awards, and leave actions and the creation of travel orders to name only a few. Thus, Marines in the G-1 section became involved in the personnel actions of subordinate units, which further reduced the section's combat focus.<sup>38</sup> The division officers' lack of training and knowledge of personnel operations prevented the G-1 section from devoting its full attention to the planning process. G-1 Colonel Harvey S. Walseth, Assistant G-1 Lieutenant Colonel Bryghte D. Godbold, and Administrative Chief Master Sergeant Leslie W. Sherman flew to Japan with the division's initial planning staff. However, no elements from the division adjutant section were on the ini-

<sup>32</sup> Ibid., 9.

<sup>33</sup> Montross and Canzona, *U.S. Marines in Korea 1950-1953*, 56.

<sup>34</sup> 1st Marine Division, *Special Action Report*, 11.

<sup>35</sup> Ibid., 9.

<sup>36</sup> *Landing Operations Doctrine*, 30-31.

<sup>37</sup> Montross and Canzona, *U.S. Marines in Korea 1950-1953*, 18.

<sup>38</sup> 1st Marine Division, *Special Action Report*, 24.

tial planning staff.<sup>39</sup> For the entirety of the planning process, the G-1 section performed tasks usually executed by the division adjutant because the adjutant section did not embark on the *McKinley* until 11 September 1950.<sup>40</sup> The two most difficult adjutant tasks during the preliminary planning were the tasking to prevent all 17-year-old Marines from entering combat and the assembling, logging, and mailing of the division staff's top-secret and secret operation and administrative orders.<sup>41</sup> The understaffed G-1 section had difficulty executing the additional tasks while also fulfilling its regular requirements and contributing to Operation Chromite planning.

With limited time, staff, and resources, the G-1 section used preliminary planning and the support of the PhibGruOne staff to produce the personnel annex in time for the distribution of Administrative Order 2-50. When the division mobilization began with a notification from the Commander of Fleet Marine Forces Pacific General Lemuel Sheppard on 14 July 1950, Colonel Walseth, the G-1, realized that no standard operating procedures (SOPs) existed for combat personnel operations such as requisitioning replacements, processing casualties, and burials. During the two weeks between the initial deployment order and the departure of the division's initial planning staff to Japan, the G-1 section produced SOPs covering all combat personnel operations for the division. These included instructions and a format for personnel daily summaries to be filled out by subordinate units, a format for a unit report that included explanations for each subsection, a casualty reporting procedure that referenced chapter 13 of the *Marine Corps Manual* and included a format for a report of casualties processed, a format for an embarkation roster to be used during the amphibious assault, a set of war crimes procedures that included forms for reporting and investigating war crimes, a set of burial and graves registration procedures, and a section outlining the process for awards recommendations. Colonel Walseth initiated this effort on his own authority, and Marines of the G-1 section

produced the documents based on their own experience and competence with personnel operations.<sup>42</sup> When the G-1 section began the planning process for the Inchon landings, the section incorporated the SOPs into the personnel annex as general appendices.<sup>43</sup> The SOPs were critical to produce a complete personnel annex to Administrative Order 2-50 in only 12 days and to demonstrate the importance of competence in an abbreviated planning process.

The division's G-1 section also used the people and resources of the PhibGruOne staff to perform the planning duties of the division adjutant. The primary role of the division adjutant in the planning process is the production and distribution of orders. To accomplish this, the G-1 section required the use of the reproduction facilities onboard the *McKinley*. The PhibGruOne staff made these available to the 1st Marine Division staff without any prioritization issues or parochial reservations. Despite the G-1 section's planning requirements, the section successfully carried out all of the administrative tasks of the division adjutant as well as reproduced and distributed Operation Order 2-50 and Administrative Order 2-50 on time.<sup>44</sup> The individual competence of members of the G-1 section, combined with the productive relationship with the PhibGruOne staff, was critical to the timely completion of the personnel planning in support of the Inchon landing.

## G-2 Intelligence Planning

The short time line and initial lack of intelligence collection assets such as aerial reconnaissance or scouts in the Inchon-Seoul area produced significant problems for the undermanned division G-2 section. Only G-2 Colonel B. T. Holcomb and Assistant G-2 Major J. G. Babashanian flew out to Tokyo with the initial planning staff on 19 August. At that time, the division had an almost total lack of intelligence information for the landing beaches. Even though U.S. forces had operated out of Inchon since the end of World War II, military forces had very little detailed technical information about the har-

<sup>39</sup> See *ANNEX A G-1 Report*, in *ibid.*, 3.

<sup>40</sup> *Ibid.*

<sup>41</sup> *Ibid.*, 4-5.

<sup>42</sup> *Ibid.*, 3.

<sup>43</sup> The G-1 SOPs became appendices 1-7 of *Annex Able* attached to Administrative Order 2-50. *Administrative Order 2-50: 1st MarDiv [Rein]* (Washington, DC, 4 September 1950), <http://www.recordsofwar.com/korea/USMC/Box%202-5.pdf>.

<sup>44</sup> *Ibid.*, 5.

bor to include maps, tidal information, geology, and harbor infrastructure specifications. Due to the fluid combat situation and distance to Inchon from the Allied front lines, very limited intelligence existed on enemy defensive tactics or units in the Inchon-Seoul area in July 1950.<sup>45</sup> Additionally, the G-2 section was critically undermanned for the analysis of even the limited intelligence available at the beginning of the planning process. Operation Chromite's short planning time line, limited initial intelligence, and a personnel shortage in the G-2 section created significant planning challenges.

To effectively analyze the battlefield situation of the Inchon-Seoul area, the G-2 section leveraged outside capabilities. The PhibGruOne G-2 section briefed the 1st Marine Division G-2 section immediately on arrival in Tokyo, and the two sections collaborated to conduct a more detailed analysis of existing information. They pored over Joint Army-Navy Intelligence Service publications, strategic engineering studies, and naval attaché reports to construct a detailed understanding of the physical problems associated with the beaches. They identified abnormally high and low tides that exposed extensive mud flats for the landing area, thereby narrowing the landing window to a three to four-hour time frame two days in each month.<sup>46</sup> Through their own analysis, they also uncovered important information on the enemy's position at Inchon and the surrounding areas. They were able to analyze information from photographic interpretation reports, which allowed the G-2 sections to identify only a scattering of unoccupied defense installations.<sup>47</sup> These photographs indicated very little activity around these installations. The teamwork between the G-2 sections of PhibGruOne and 1st Marine Division staff was vital in gathering and analyzing the limited intelligence data available.

To ensure the 1st Marine Division G-2 was capable of the difficult planning tasks required by the Inchon landing, the section was augmented with significant joint assets. Early in the planning process, FECom allocated both Army and Republic of Korea assets

to support the G-2 section. The assets included the U.S. Army's 163d Military Intelligence Service Detachment and the 441st Counter Intelligence Corps. The highly specialized competence of the units in conjunction with the amphibious expertise of the 1st Marine Division G-2 section produced a powerful joint intelligence team. Due to the increased capabilities from the additional assets, the G-2 section was able to direct the ongoing prisoner of war interrogations of the U.S. Eighth Army, which was engaged in combat operations hundreds of miles away.<sup>48</sup> This enabled the G-2 section to write an enemy estimate that proved to be surprisingly accurate about the enemy situation in the Inchon-Seoul area. The estimate ensured the detail and completion of the intelligence annex and paragraphs contained in Operation Order 2-50. Incorporating the competence of outside intelligence organizations through close teamwork allowed the G-2 section to complete its intelligence estimate on time.

### G-3 Operations Planning

For the G-3 section, the planning phase commenced on 19 August after G-3 Colonel A. L. Bowser Jr. and Assistant G-3 Lieutenant Colonel F. R. Moore arrived in Tokyo with the initial planning staff. These two officers were responsible for the majority of the tactical planning for Operation Order 2-50. However, creating a detailed plan for the Inchon landing was impossible without additional support. The G-3 section produced the base plan for Operation Order 2-50 by incorporating officers from across the division and by relying on other division staff directorates and PhibGruOne staff. With only the G-3 and assistant G-3 officers acting as the operations planning section, division Chief of Staff Colonel G. A. Williams augmented the G-3 section with the division's antitank officer and two tactical observers.<sup>49</sup> He attached the officers to the G-3 section as assistant operations officers in addition to 11 enlisted Marines who provided administrative support during the orders production process. The section functioned well with the augmentees, because although

<sup>45</sup> See *ANNEX B G-2 Report*, in *ibid.*, 2, 8.

<sup>46</sup> *Ibid.*, 2-3.

<sup>47</sup> *Ibid.*, 3.

<sup>48</sup> *Ibid.*

<sup>49</sup> *ANNEX C G-3 Report*, in *ibid.*, 2-3.

they had little training or experience in planning, they had a great deal of experience in amphibious operations. These augmentee officers reflected the overall experience of the 1st Marine Division Staff, the majority of which served in WWII.<sup>50</sup> The officers enabled the G-3 to supervise the planning process, make field visits, and attend conferences with higher and subordinate units. This freedom of movement was key to the functioning of the G-3 section and increased the quality of planning for all operations.

As a landing beach, Inchon and the surrounding area presented a tactical problem that required the G-3 to use the entire division staff's competence in conducting amphibious operations. The G-3 section planned the landing with an initial attack on Wolmi-Do Island 11 hours before the main landing. The planners realized they needed to address the island first because of the physical advantage it gave the enemy in defending the beaches. The G-3 section based this assessment on the G-2 analysis of both the geographical complexity of the Inchon area and the enemy situation. During the planning process, the G-2 analysts identified extremely steep seawalls that protected the rear of the city. With this information, the G-3 was able to identify the need for scaling ladders in time for their procurement prior to the landing. This teamwork amongst the staff sections allowed the G-3 to plan an envelopment of Inchon and contributed to its successful execution. The analysis of the Inchon sea conditions was another critical element of the landing plan. With the G-2 assessment of the tides and the G-3 section's amphibious experience, the G-3 section determined that the landing had to begin at 1730 to have enough daylight to reach all initial objectives.<sup>51</sup> Even with a compressed time line, the G-3 section created an extremely detailed Operation Order 2-50 that synchronized the actions of several different maneuver elements for a successful landing. Teamwork allowed the G-3 section to collect all necessary information to plan the landing. The section's competence in amphibious operations allowed for fast turnover, completing the operations order in only 12 days.

## G-4 Logistics Planning

Along with a short planning time line for Operation Chromite, the lack of available shipping and the unpredictable nature of trans-Pacific operations challenged the 1st Marine Division's logistics planning. Knowing only that the division would be participating in an amphibious operation, the G-4 section used available shipping assets to load and transport the division's equipment and personnel.<sup>52</sup> The transportation available at such short notice fell well below the assets required for the combat deployment of a Marine division. The lack of transportation assets prevented all of the division's units from being loaded in a combat configuration which allows those units to drive their equipment off of the transport ships and directly into combat. Some units were organizationally loaded, which meant they were unable to roll their equipment off of the ships and into combat but instead were reloaded prior to combat. In addition to the deployment time line, several shipping events occurred that limited the flexibility of the division's logistics operations. These events included a typhoon that hit the Port of Kobe, Japan—which was the division's main assembly area in FECom prior to the operation—and the loss of one of the division's cargo ships to a fire.<sup>53</sup> These challenges made the logistics planning and execution for the Inchon landing as difficult as the tactical problems.

The lack of adequate shipping required the G-4 section to decide which units to combat load and which units to organizationally load based on their experiences conducting amphibious operations. With very little detailed knowledge of future operations, the G-4 section decided to combat load two battalions while organizationally loading the rest of the division.<sup>54</sup> The section intended to combat load the remainder of the units once they arrived in theater. However, Typhoon Jane struck Kobe on 3 September 1950 and stopped logistics operations for a critical 36-hour period, which prevented the reloading of any of the division's units. Therefore, the units combat loaded in Camp Pendleton, California, were the only combat units available for the operation

<sup>50</sup> 1st Marine Division, *Special Action Report*, 11.

<sup>51</sup> *Ibid.*, 3.

<sup>52</sup> ANNEX D G-4 Report, in *ibid.*, 4.

<sup>53</sup> *Ibid.*, 7.

<sup>54</sup> *Ibid.*, 6-7.

and became the first wave of the Inchon landing. If the G-4 had decided to organizationally load the entire division to get it into theater faster, the division would not have made the 15 September landing date. These decisions, based on the knowledge and experience of the G-4 section, represented a high level of competence.

Like the rest of the staff, only a small G-4 section flew out to Tokyo on 22 August as part of the division's initial planning staff. The section included G-4 Colonel F. M. McAlister and Assistant G-4 Lieutenant Colonel C. T. Hodges. The remainder of the G-4 section stayed at Camp Pendleton as the division completed its mobilization, embarkation, and departure for Korea. Part of the planning for Operation Chromite required the G-4 section to stage and supply the units in theater. As the main assembly area in Kobe did not have sufficient space, the division spread out over a large area. When the SS *Noonday* caught fire with a hold full of combat uniforms and other equipment, the G-4 section operating between Kobe and Tokyo had to repair the equipment on-site. The section coordinated with the Salvage Agency of Kobe Base Command to repair, clean, dry, and repack the equipment essential to the division's sustained combat operations. Marines in the section used personal contacts with Army salvage personnel, who were themselves operating away from their higher headquarters. Salvaging the equipment and avoiding any delay in the deployment schedule was a testament to the G-4 section's ability to work with their Army counterparts as a team. In this instance as with the entire operation, the division staff attributed the logistical success of Operation Chromite to the "ingenuity and good judgment" of the staffs and units from the division.<sup>55</sup> During the operation, no division element ran short of mission essential equipment or supplies. The competence and teamwork of the G-4 section allowed the 1st Marine Division's logistics operations for the Inchon landing to be a success.

## Conclusion

For the 23 staff officers on the 1st Marine Division's initial planning staff, preparing for the Inchon land-

ing—which involved nearly 30,000 Marines and soldiers in only 23 days—was an impossible task. The geographical and maritime conditions of the Inchon harbor were among the most difficult of any port in the world, and staff could not blindly apply doctrinal templates to the tactical problems. The 1st Marine Division staff officers relied heavily on their collective amphibious experiences, their competence as staff officers, and a close working relationship with the PhibGruOne staff; thus, the division staff produced an operation and administrative order in only 12 days to ensure enough time for distribution of that order to the division's dispersed units prior to the movement to Inchon. This close working relationship developed without direction from FECom, CJTF-7, or X Corps, as the rapidly changing situation in theater prevented close coordination or synchronization of the headquarters activities.<sup>56</sup> Several interconnected factors led to such a productive working relationship under very difficult circumstances.

Military professionals and historians alike believe that military officers do not read their own doctrine. If they do read it, they do not follow the doctrine, but instead rely on pragmatic decision making based on changing circumstances. The officers of the 1st Marine Division across all sections of the staff were well versed in their amphibious assault doctrine without requiring refresher training or additional staff exercises before departing California for Japan. Division staff understood the process for producing a complete order and what to expect in working with their naval peers. But also, the staff's knowledge of the amphibious assault doctrine was essential for integrating with the PhibGruOne staff so effortlessly and producing a complete order in such a short amount of time.

The division staff worked with the PhibGruOne staff across all joint functions of command and control, movement and maneuver, intelligence, and sustainment. However, the importance of the teamwork between different staffs, operating in a joint operation, cannot be overlooked. Often staffs in the same chain of command have adversarial relationships due to strong personalities and the command climate established by commanders. Additionally, the potential exists for commanders and staffs to remain

<sup>55</sup> Ibid., 6.

<sup>56</sup> John R. Ballard, "Operation Chromite: Counterattack at Inchon," *Joint Forces Quarterly* 28 (2001): 33.

committed to parochial pursuits to the detriment of the joint endeavor, especially when one of the staffs is a joint organization and the other a service component headquarters staff (Currently, each Geographic Combatant Command has a headquarters from the Army, Navy, Air Force, and the Marine Corps that are designated as service component headquarters).

For example, in 2011, the staffs of the Joint Task Force Odyssey Dawn (a joint command of officers and noncommissioned officers from all Services) and Joint Force Maritime Component (comprised primarily of naval officers) were colocated onboard the USS *Mount Whitney* (LCC 20), the “U.S. contribution to a multilateral military effort to enforce a no-fly zone and protect civilians in Libya.”<sup>57</sup> While the commands experienced mutual cooperation, both staffs worked concurrently on their own functional efforts. The additional efforts overworked the staff officers and blurred lines of communication and authority between the staffs, which led to coordina-

tion issues from near instantaneous communication across the joint task force to disregarding the organizational chain of command.<sup>58</sup> *Doctrine for the Armed Forces of the United States* states that adherence to the principles of professionalism is every joint officer’s responsibility.<sup>59</sup> However, an equally strong requirement for commanders, chiefs of staff, and staff directorate leads is to actively encourage and inculcate a climate of professionalism in their staffs. Without this command reinforcement, the collective efforts of staffs, such as those with 1st Marine Division in Inchon, cannot leverage the competence of their members while simultaneously creating a joint team with other staff organizations operating in the same area of responsibility. Often thought to be the purview of only commanders, the planning effort of the 1st Marine Division Staff for the Inchon landing demonstrates that professionalism is a requirement for staff officers as much as it is for commanders in combat operations. ♦1775♦

<sup>57</sup> Jeremiah Gertler, *Operation Odyssey Dawn (Libya): Background and Issues for Congress* (Washington, DC: Congressional Research Service, 2011), 1.

<sup>58</sup> Joint and Coalition Operational Analysis (JCOA), *Libya: Operation Odyssey Dawn (OOD): A Case Study in Command and Control* (Suffolk, VA: JCOA, 2011), 6-7.

<sup>59</sup> Office of the Joint Chiefs of Staff, *Doctrine for the Armed Forces of the United States*, B-1, B-3.

# National Museum of the Marine Corps:

## MOVING FORWARD TO TELL THE STORY OF TODAY'S WARRIOR

**M**ore than a year ago, the National Museum of the Marine Corps (NMMC), in cooperation with the Marine Corps Heritage Foundation, broke ground to fulfill a nine-year-old commitment to be the home for *all* Marine Corps history. When the work is finished on this 126,000-square-foot Final Phase (the name coined for this project), NMMC will have more than doubled in size, and the circle, as well as the Corps' story, will be complete.

Included in the new spaces will be not only historical galleries covering the Corps' history from 1776 to the present, but also a giant-screen theater, an expanded education suite and children's gallery, a combat art gallery and studio, a Hall of Valor, and a Marine Corps Sports gallery, as well as a changing exhibits gallery.

Much has happened since the groundbreaking, both on the building and with defining the design and content of the new spaces. As construction crews have been taking down existing walls and building new ones, the Final Phase team has been finalizing plans for how to tell the story in the most compelling way. The museum's exhibit design team has been shaping the visual story, while a team of writers from NMMC and historians from Marine Corps History Division has been crafting the written storyline. Design development is complete.

"It's imperative that we get these galleries right because the memories of recent wars are so very fresh. The sense of pride and of loss is still raw, especially for visitors who have recently lost loved ones in Iraq and Afghanistan. This is the most important thing we've done yet; these galleries will honor warriors in uniform today," Lin Ezell, NMMC director, said.

To get the story right, the museum put together



*Photo courtesy of the National Museum of the Marine Corps*  
An artist rendering of the Desert Storm/Desert Shield exhibit for the final phase of the National Museum of the Marine Corps.

a diverse group of senior advisors to guide the process and to ensure that the whole story is told. The new historical galleries will tell of Marines in both combat and humanitarian efforts, as well as on the home front. These galleries will communicate every Marine's story because, while not every one of them served in combat, they are each important to the mission. The senior advisors told the team that if they do not tell the Marine family story they "will have missed the mark." The team took that to heart and has not only included an exhibit on the Marine family, but has also woven it into the overall exhibition. At current count, 575 artifacts have been chosen to illustrate Marine Corps history in the new galleries. These include everything from a McDonnell Douglas F/A-18 Hornet to a set of blood-crusted ribbons.

"When telling the story of 'no better friend, no worse enemy,' there's no museum better positioned to do this than the National Museum of the Marine Corps," Ezell said. ♦ 1775 ♦

*For more information about the National Museum of the Marine Corps, please call 703-784-6107 or visit the museum's website at [www.usmcmuseum.org](http://www.usmcmuseum.org).*



## BOOK REVIEW

# *Shooting the Pacific War: Marine Corps Combat Photography in WWII*

Review by Charles Grow  
Deputy Director  
National Museum of the Marine Corps

*Shooting the Pacific War: Marine Corps Combat Photography in WWII.* By Thayer Soule. (Lexington: University Press of Kentucky, 1999. Pp. 272. \$40.00 cloth and e-book.)

Thayer Soule's memoir, *Shooting the Pacific War*, discusses the genesis of a formal Marine Corps combat photography program and records the author's experiences in establishing a photographic effort from scratch, through its proof of concept at Guadalcanal and battle testing at Iwo Jima. Soule's story resonates with authenticity and humility. Although a veteran of both Guadalcanal and Iwo Jima, the author comes across as accessible and relatable because of his self-deprecation and humor. His reliance on a personal journal and historical references help Soule accurately tell a little-known story.

As America entered World War II, all of the Services faced the daunting challenge of exponential expansion, recruiting and training huge numbers of young Americans. Each Service used still and motion photography for recruitment and training. To achieve their goals, the U.S. Army, Navy, and Marine Corps vigorously recruited professional photogra-

*Charles Grow, captain, USMC (Ret), serves as deputy director of the National Museum of the Marine Corps, Quantico, Virginia. He deployed to the Gulf War, Somalia, Haiti, Cuba, Afghanistan, and Pakistan as a combat artist and photographer. Grow served as the 1st Marine Division combat camera officer from 1995 to 1998.*

phers to establish, equip, and train new photographic units. Collectively, these military cameramen provided the country with a previously unprecedented collection of images that shaped America's understanding of war and the challenges faced by its warriors. Both the Army and the Navy developed fairly robust photographic

programs. The Navy's vaunted Aviation Photographic Unit, led by Commander Edward J. Steichen, produced a body of work that is well documented in Mark D. Faram's *Faces of War: The Untold Story of Edward Steichen's WWII Photographers* (2009). The Army's Signal Corps had signal photo units spread throughout the European and Pacific theaters; much of their work is stored at the National Archives and Records Administration. Ralph Butterfield, an Army photographer during World War II, edited *Patton's GI Photographers* (1992), which suggests that the Army's use of photography was also better planned and resourced than the Marine Corps' program.

Karl Thayer Soule Jr. was a Harvard-educated American film documentarian in Holland before Adolf Hitler's advance forced him to return to the United States. Hoping to put his talent and skills to work in support of the American war effort, Thayer

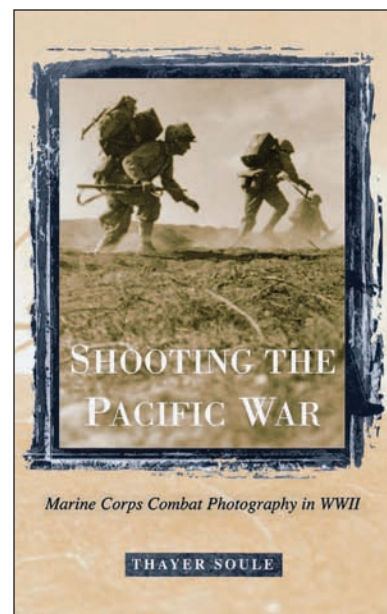

contacted the Army to join the Signal Corps and become a combat camera officer. However, an old friend got Soule an interview with Brigadier General Robert L. Denig at Headquarters Marine Corps. Within days, Soule was directly commissioned a second lieutenant. Soule felt at a loss for not experiencing Officer Candidates School or The Basic School, but he made the most of this new opportunity. Smart enough to listen and admit when he did not know something, Soule was a quick study and soon proved to be a capable leader, excellently prepared to help establish and develop the Marine Corps' fledgling combat camera program.

Stationed at Quantico, Virginia, in building 2009, which continues to house U.S. Marine Corps Combat Camera today, Second Lieutenant Soule learned the ropes of being a Marine officer and leader. He helped to establish equipment requirements and rigorous field training and to develop the tactics, techniques, and procedures for the combat photographers he would soon lead at Guadalcanal. Resourceful and driven, the new lieutenant worked hard to get atypical equipment and supplies from a quartermaster system better suited to buying helmets and rifles. That reality continues to be a challenge to combat camera Marines today.

Soule and his Marines were ready by the time they deployed to Guadalcanal. They tested their theories and made adjustments where needed. Soule was in the 1st Marine Division's G-2 (intelligence) section, where he championed the value of photography for intelligence, training, operations, and historical documentation. His commander, Colonel Frank B. Goettge, asked him, "Now you can clear up a mystery for me. What the hell is a photographic officer?" (p. 27). Like most new lieutenants, Soule also inherited additional duties. He was responsible for making, printing, and distributing tactical maps as well as producing a steady volume of aerial reconnaissance photographs. Slowly, the senior officers warmed to the new technology and the value it added to the warfighting effort. By the end of the Guadalcanal campaign, the 1st Marine Division combat camera crew was battle tested and ready for rest and refit. However, their photographic work was largely unimpressive, according to Peter Maslowski, professor of history and author of *Armed with Cameras: The American Military Photographers of World War*

*II* (1993). According to Maslowski, Soule said, "We just plain and simple didn't have the equipment, didn't have the film, didn't have the people." Soule left the Pacific and returned to Quantico to train another group of greenhorns.

Captain Soule spent just more than a year at Quantico, incorporating lessons learned from Guadalcanal into the classes and tactics taught to new photographers. He worked hard to prepare the men for combat because some of them were headed to 3d Marine Division with Soule, where they would participate in the Iwo Jima campaign. This tour was different; Soule joined the 3d Marine Division after the unit had fought through Bougainville Island and Guam. He checked into the division headquarters, where he found a slipshod combat camera section that had not had an officer for months. Major General Graves B. Erskine grilled the young officer, looking for an executable plan that would net good results for the division. Soule's thoughtful and detailed plan impressed Erskine and may have kept Soule from becoming the mess officer. With little time to prepare and a significant portion of the team overdue for stateside rotation, Soule's rigorous training and effective leadership had the men ready just in time for the Battle of Iwo Jima, for which he and some of his men were decorated for their service. His section suffered casualties, and Soule struggled to deal with the wounded and dead. Before the battle ended, he was dispatched to Quantico on urgent business.

By 1945, the United States was on its seventh bond drive, which featured a painting of Joseph J. Rosenthal's photograph of the flag rising at Iwo Jima. The Japanese code of *Bushidō*, whereby duty supersedes everything, continued to demand a high cost in lives and limbs as Americans moved toward the emperor's homeland. Soule's urgent business at Quantico had involved a team putting a film together about Iwo Jima; their efforts received positive public reviews and earned an Oscar nomination. He also worked on procuring new camera equipment before proceeding to Headquarters Fleet Marine Force, Pacific, located in Hawaii. While there, he trained another new crop of combat photographers for the pending invasion of Japan. However, two atom bombs eliminated the need for a full-scale invasion of Japan; Soule and his men went back to civilian life where several of them enjoyed long and productive careers in the film business.

Soule's book is an interesting and balanced read, written by an intelligent and unassuming young officer who saw the rapidly growing wartime Corps from a fresh perspective. The book documents Soule's transformation from a direct commissioned second lieutenant to a combat veteran of one of America's

seminal battles. The work stands as a good companion to Charles Jones's *War Shots: Norm Hatch and the U.S. Marine Corps Combat Cameramen of World War II* (2011), and Joe O'Donnell's *Japan 1945: A U.S. Marine's Photographs from Ground Zero* (2005).

◆1775◆

## BOOK REVIEW

# War's Nomads: A Mobile Radar Unit in Pursuit of Rommel during the Western Desert Campaign, 1942–3

Reviewed by Douglas E. Nash  
Historian, History Division  
Marine Corps University

*War's Nomads: A Mobile Radar Unit in Pursuit of Rommel during the Western Desert Campaign, 1942–3.* By Frederick Grice. Edited by Colin and Gillian Clarke. (Oxford: Casemate Publishers, 2015. Pp. 240. \$34.95 cloth.)

Radar technicians are seldom the subjects of serious historical study, particularly when comparing their mundane specialty to more glamorous occupations, such as paratrooper or fighter pilot. But similar to other military specialties, radar technicians do their part to defend against or strike back at the enemy. *War's Nomads: A Mobile Radar Unit in Pursuit of Rommel during the Western Desert Campaign, 1942–3* is the story of one man's experiences in Unit 606, a Royal Air Force (RAF) improvisation created to rapidly field deployable light Type 6 radar sets, specifically designed to provide early warning to forward airfields. Though such obscure units gained little attention during the war and were forgotten quickly after-

ward, Fred Grice's account (more of a travelogue than a memoir) fills a gap in the historical record, shining a light on what everyday life was like for those operating at the margins of "the big war" in North Africa.

Grice had been a public school teacher and amateur historian until drafted in 1941 at the age of 31. He first served as an enlisted aircraftsman ("Erks" in RAF slang) in North Africa and later as a flight officer in East Africa until the end of the war. *War's Nomads*, edited by Grice's daughter and son-in-law, is based on three wartime accounts that Grice wrote but never published. He provides a fascinatingly detailed look at life in an exotic unit during a critical period in the campaign—that of the immediate aftermath of German Field Marshal Erwin Rommel's defeat at the first battle of El Alamein in August 1942 until the beginning of the Allied assault into Tunisia in March 1943. During his seven months of active service with British Army Field Marshal Bernard L. Montgomery's Eighth Army, Grice and his team of Erks—usually fewer than 10 men—operated in an austere environment at the far end of the British logistical system. Grice's team scrounged for such basic necessities as food, water,

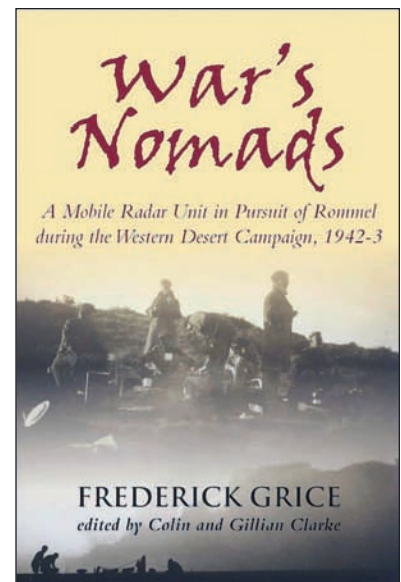

*Douglas E. Nash, colonel, USA (Ret), works as a writer/researcher at History Division, Marine Corps University, Quantico, Virginia. He is the author of Hell's Gate: The Battle of the Cherkassy Pocket, January to February 1944 (2002) and Victory Was Beyond Their Grasp: With the 272nd Volks-Grenadier Division from the Hürtgen Forest to the Heart of the Reich (2008). Nash is currently researching Marine Corps amphibious warfare for an upcoming USMC History Division anthology.*

clothing, and repair parts for their ancient Crossley truck, which carried the team's radar set.

The book is divided into two sections. The first, "On Draft," is his monograph focusing on his entry into the RAF, specialty training, and voyage on a troopship around the Cape of Good Hope of South Africa to Egypt. The second section, "Erk in the Desert," is a companion piece that describes his experiences in Egypt and the Libyan Desert until his transfer to East Africa. The works stand on their own, but when brought together and reinforced by entries from an unauthorized daily journal (Grice's "black book"), the reader gets a broader, more comprehensive account of everyday life experienced by the enlisted men who served in the British armed forces during this crucial period of the war.

Readers of Richard Tregaskis's *Guadalcanal Diary* (1943) will recognize some of the aspects of the long voyage onboard a troopship, which Grice recounts in "On Draft." While Tregaskis's weeklong voyage from Australia to Guadalcanal onboard the decrepit liner USS *American Legion* (AP 35) was no picnic, Grice's two-month voyage around the southern tip of Africa and up through the Suez Canal was a grueling affair. The food onboard the cramped British troopship HMS *Highland Monarch* was bad, accommodations were poor, and worse still was the chasm between living conditions experienced by the "other ranks" (as British enlisted men were known) and officers, whose trip was nothing less than a pleasure cruise, enjoying the privileges of rank bestowed upon them by a system nearly unchanged in 400 years. Grice and 250 of his fellow RAF aircraftsmen were elated when they reached Alexandria, Egypt, in August 1942 and disembarked for dry land. But that marked only the beginning of the author's hegira.

Grice's next adventure, as recounted in "Erk in the Desert," was his journey from Egypt across the Western Desert to the gates of Tunisia, where Rommel's desert army was finally brought to bay after its crushing defeat at the second battle of El Alamein in October 1942. Closely following the British spear-

head, Grice and his team set up and operated radar equipment that enabled RAF fighter aircraft to operate close to the front lines without fear of an Axis surprise attack by the dreaded Messerschmitt and Stuka German aircraft. Living in the open desert with few of the amenities enjoyed by today's soldiers, Grice and his comrades eked out a bare existence, making do with little and scrounging as much as they could. His meals usually consisted of tea, biscuits (hard crackers), some occasional marmalade, and the dreaded M&V (meat and vegetable) canned ration. Often living in a log-covered hole scooped out of the desert floor, Grice treasured his privacy at night, using his precious free time between his duties onboard the Crossley gharry (truck) to write in his journal, compose poetry, and weave vivid descriptions of desert sights and sounds.

Living a nomad existence for nearly seven months, Grice was recalled to East Africa on 19 March 1943, the same day the Eighth Army launched its counteroffensive into southern Tunisia. Surprised by the suddenness of his posting, he was relieved yet simultaneously saddened to leave his tight-knit group with little time to say farewell. After the war, Grice reunited with his family and resumed his career as an educator and administrator. He devoted increasing amounts of his free time toward historical research and professional writing, finding a measure of success in publishing children's stories and local English histories before his death in 1983. Grice's contribution to military history, though limited to this one posthumous work, is significant in that it highlights a little-known chapter of the war in North Africa. Its only shortcoming is that the author never wrote about Unit 606's actual mission—operating as a rapidly deployable radar warning station. Though no doubt constrained by operational security considerations of the time, an actual description of how the equipment functioned and was employed would have shed additional light on the military specialty, but this hardly detracts from Grice's account.

◆ 1775 ◆

## BOOK REVIEW

# Marine Corps Tank Battles in the Middle East

Reviewed by Paul Westermeyer  
Historian, History Division  
Marine Corps University

*Marine Corps Tank Battles in the Middle East.* By Oscar E. Gilbert. (Havertown, PA: Casemate Publishers, 2015. Pp. 312. \$34.95 cloth.)

The U.S. Marine Corps is renowned as an infantry force and not usually associated with armored fighting vehicles or main battle tanks. The Corps, however, is a modern combined-arms force, and Marine tankers existed long before Marine divisions. Oscar E. Gilbert has written a series of books describing Marine tanks in action. *Marine Corps Tank Battles in the Middle East* is the latest entry in this series, which includes *Marine Tank Battles in the Pacific* (2001), *Marine Corps Tank Battles in Korea* (2003), and *Marine Corps Tank Battles in Vietnam* (2007). Gilbert's new work covers Marine tank engagements from the 1990–91 Gulf War to recent operations in Afghanistan.

Often Marine tanks supported Marine infantry operations. Marine tanks engaged enemy tanks in World War II and the Korean War; but during the Gulf War, the Corps operated mechanized forces against enemy armored divisions on a scale not previously seen. Both the 1st and 2d Marine Divisions operated with two tank battalions, and the 2d Marine Division—with the U.S. Army's 1st (Tiger) Brigade, 2d Armored

Division, under its operational command—formed a de facto armored division with more than 250 tanks and 350 armored fighting vehicles. Marine tanks plowed through the fixed Iraqi defenses on the first day of the campaign and destroyed an Iraqi armored counterattack on the morning of the second day.

I Marine Expeditionary Force then swept north to liberate Kuwait City. Gilbert devotes two chapters to this seminal event in Marine Corps armored history.

He provides a short chapter on the background of the Taliban, the 9/11 attacks, and light armored vehicle (LAV) operations supporting Task Force 58 during initial operations in Afghanistan. Four chapters are devoted to the role of armor in the 1st Marine Division's mechanized column during the 2003 invasion of Iraq, including the fratricide-plagued battle of an-Nasiriyah. This fighting was in some ways more intense and costly than the larger tank-on-tank engagements of the Gulf War. Several tank-on-tank engagements occurred during the march on Baghdad, primarily against Iraqi Army T-55 main battle tanks, which the Marine M1A1 Abrams main battle tanks destroyed somewhat easily.

Gilbert also describes the use of armor in the counterinsurgency operations that dominated events after the initial invasion in 2003, including the Second

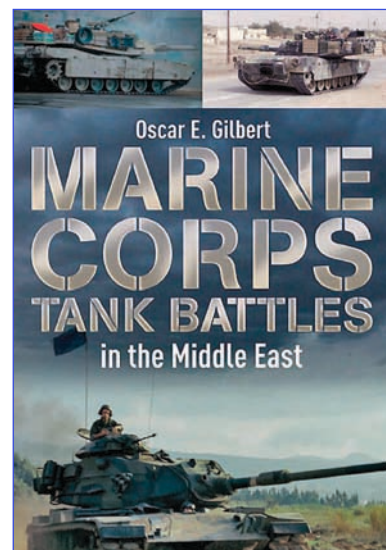

*Paul Westermeyer is a historian at the U.S. Marine Corps History Division, Quantico, Virginia. He is the author of U.S. Marines in the Gulf War, 1990–1991: Liberating Kuwait (2014) and U.S. Marines in Battle: Al-Khafji, 28 January–1 February 1991 (2008).*

Battle of Fallujah where Marine tanks were forced to support the infantry in brutal house-to-house fighting. The book concludes with a chapter on the more limited role armor played in the wind-swept mountains of Afghanistan where the Marine presence was beefed up in 2010.

Two threads run throughout the book. One is the 1st Tank Battalion, which played a key role in Marine operations during the liberation of Kuwait in 1991, helped seize Baghdad in 2003, and helped clear Fallujah in 2004. The second thread is the emergence of Marine LAVs during this period. The vehicles were wheeled and armed with 25mm chain guns; 81mm mortars; tube-launched, optically tracked, wire-guided (TOW) antitank missiles; and infantry fire teams. The LAVs provided the Marines with a lighter armored option and increased the flexibility of the Marine air-ground task force compared with those used in the early 1990s.

Gilbert's writing is clear and concise and immerses the reader in the immediacy of the action. His book contains numerous footnotes with primary

and secondary sources; however, he favors memoirs and oral history interviews and misses key secondary sources on the topic. His citations are at times sloppy; he continuously misnames the reviewer when citing the book on al-Khafji, for example. The focus on first-person accounts adds to Gilbert's interesting prose but reduces the coverage of his work. The book cannot be considered a comprehensive historical account of Marine armor operations in the Middle East, but the work covers the topic sufficiently nonetheless.

Prior to Gilbert's book series, Marine armor operations was often an ignored topic covered solely by fringe publications and aimed at hobbyists and model builders more than at military readers. He treats the subject with historical gravitas and shows that Marine armor includes more than just amphibious attack vehicles. The book's quality, however, suggests a rushed publication, which explains the missing sources, but the book remains a key work for Marine armor in support of Marine infantry operations.

◆ 1775 ◆

## BOOK REVIEW

# Hirohito's War: The Pacific War, 1941–1945

Grant W. Jones  
Instructor of American and Military History  
Southern New Hampshire University and Ashford  
University

*Hirohito's War: The Pacific War, 1941–1945.* By Francis Pike. (London: Bloomsbury Publishing, 2015. Pp. 1152. \$45.00 cloth; \$45.99 e-book.)

**H**irohito's *War* by Francis Pike offers a comprehensive history of the East Asia/Pacific war between Japan and the Allied powers. The title is somewhat misleading on two counts. The author devotes much of the book to the war on the Asian mainland both before and after 1941. The first 150 pages of the work explain the causes and events leading up to the conflict in the Pacific theater. The author's narrative successfully strikes a balance among the four main areas of conflict: the Central Pacific, the South Pacific, China, and Southeast Asia. By doing so, Pike illustrates the interconnections in Allied and Japanese strategy and logistics. While Emperor Hirohito is an important figure in the narrative, he is not the book's central focus. Pike does view the emperor as being involved in both the decision to go to war and the wartime strategy. However, the author does not consider Hirohito a leader with total power. The emperor had to accommodate many powerful, independent interest groups in Japan, including the military. Pike does not see Hirohito as the war's "arch villain" as Hitler was in Europe. But,

*Grant W. Jones is an instructor of American and military history for Southern New Hampshire University and Ashford University, San Diego, California. He has been published in War & Society and is working on an article about the China Air Task Force.*

Hirohito was also not a passive non-entity "invented by the elaborate post-war propaganda" (p. xxxiii).

Pike maneuvers between theaters and continents with out losing the reader. The book has seven parts, each one devoted to a specific time leading up to or occurring during the war. The chapters in each part discuss the relevant events in every major theater. The result is a seamless narrative, though with some overlap and avoidable repetition.

The book treats the Asian mainland as a vital theater of the conflict that merits sufficient coverage. Pike provides some conclusions that contradict current historical mainstream conclusions, and his views on U.S. Army General Joseph W. Stilwell should be given serious consideration. Barbara W. Tuchman's positive portrayal of the general in *Stilwell and the American Experience in China, 1911–1945* (1971) still dominates the historiography of the war with Japan on this issue. Pike correctly judges that Stilwell's tenure as senior American commander in East Asia had a detrimental effect on the war effort and American interests in the region. Pike views Stilwell as "in large part responsible for the ICHI-GO debacle" and one who "took comfort from the defeats of the Chinese Army" (p. 726). Pike creates an unpleasant picture of a petty man way out of his depth and a man who actually undercut the Allied

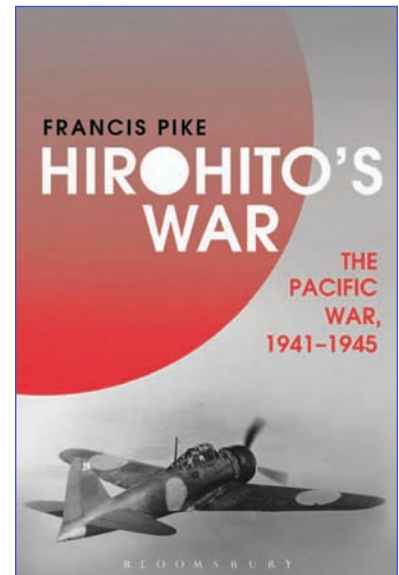



war effort to further his personal agenda. Other recent works, such as *The Battle for China: Essays on the Military History of the Sino-Japanese War of 1937–1945* (2011), indicate that a major reevaluation on this topic is required.

There are two significant shortcomings in this edition that could be rectified in future printings. The book's citations, maps, and several important appendices (on submarine warfare, economics and production, and the kamikazes) are made available online but are not in the print edition. This practice is inconvenient, particularly with the citations and maps. Hopefully, other scholarly presses will not fol-

low this publishing model that disconnects the reader from important content. The other problem for this reader was the sheer number of errors that made it through the editing process. For example, in the book's opening chapter on the causes of World War I, "Ultimately it was Germany's invasion of neutral Belgium, required by the *von Schlieffen Plan's* attempt to outflank France's defensive Maginot Line. . . ." (p. 17, italics in original). The publisher should fix such glaring mistakes, along with the random use of italics, for the next edition. Such corrections would improve the value of this comprehensive and useful work. ♦ 1775 ♦

## BOOK REVIEW

# *D-Day in the Pacific: The Battle of Saipan*

Reviewed by Mark R. Folsie  
University of Alabama History Department,  
Tuscaloosa Alabama

*D-Day in the Pacific: The Battle of Saipan.* By Harold J. Goldberg. (Bloomington: Indiana University Press, 2007. Pp. 296. \$29.95 cloth; \$23.99 e-book.)

Harold Goldberg's *D-Day in the Pacific* is a narrative account of the June 1944 Battle of Saipan between naval and military forces of the United States and Japan. Using e-mails and personal interviews from surviving veterans as well as a myriad of published memoirs and secondary sources, Goldberg reconstructs the terrible carnage on the island of Saipan to illuminate several important aspects of the battle. First, he argues that the Japanese hastened their own defeat during the battle by conducting costly and foolhardy frontal assaults on U.S. positions that wasted manpower. Goldberg also sheds light on the inter-Service rivalry between the U.S. Army and the Marine Corps during the battle. He contends that Marine Lieutenant General Holland M. Smith caused unnecessary tension between the two services by wrongfully questioning the bravery of the 27th Infantry Division and by removing its commander, Army Major General Ralph C. Smith, from command. Ultimately, Goldberg argues that Saipan was a strategically crucial and decisive battle "that has been largely forgotten" as a result of other events, such as Iwo Jima and the Allied landings at Normandy (p. 6). These represent familiar interpretations to World War II scholars; however,

*Mark R. Folsie is a PhD candidate at the University of Alabama History Department, Tuscaloosa Alabama.*

Goldberg succeeds admirably in bringing contemporary readers' attention to this terrible battle.

Goldberg demonstrates to readers throughout the book how Japanese *banzai* tactics (mass attacks) wasted critical manpower and negated the island's natural defenses. He argues that the Japanese "emerged from their

caves and protective strongholds to pursue an offense battle plan that allowed the marines and soldiers to destroy the Japanese soldiers, tanks, and equipment" (p. 2). Leaving their concealed and fortified positions in the jungles and hills of Saipan to assault American positions headlong, the Japanese were exposed to terrific Navy, Marine, and Army firepower and committed a major "strategic and tactical error" (p. 2). However, Goldberg recounts how one of these counterattacks, or *gyokusai* (to die with honor), nearly overran elements of the 27th Infantry Division on 6–7 July. Believing that the Japanese were spent, U.S. forces were shocked when more than 4,000 Japanese soldiers nearly broke through the extreme left of the American line. The fighting was horrific: the 105th Infantry Regiment killed more than 2,000 Japanese during the attack but suffered a casualty rate of 80 percent (p. 182). Goldberg suggests the Japanese could have caused more U.S. casualties and held out longer if the Japanese had adopted more defensive tactics such as those that came later at Iwo Jima.

While some historians have pointed to the differ-

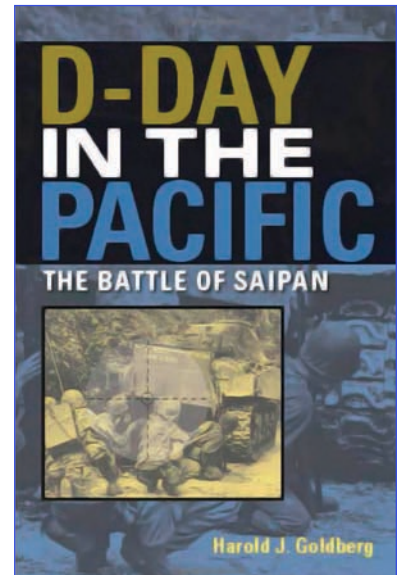

ences in tactics employed by Marines and the Army, Goldberg blames Holland “Howlin’ Mad” Smith for the acrimony between the Army and the Marine Corps that developed during, and continued after, the battle. Holland Smith ordered Ralph Smith to advance with two battalions of the 105th Infantry Regiment on 23 June to “mop up” the Japanese defenders on the Nafutan Peninsula. Holland Smith relieved Ralph Smith after the latter ordered his troops to hold the line until they could organize for the offensive (pp. 150–51). Holland Smith took this as an act of disobedience and a lack of aggressive spirit. Goldberg, however, accuses Holland Smith of being inflexible and not considering the challenges that the 27th Infantry Division encountered. The author notes that Ralph Smith’s soldiers faced thousands of well-prepared Japanese soldiers, not a few hundred that Holland Smith believed present. Goldberg argues that Holland Smith should have trusted the subordinate Smith’s judgment and allowed for adjustments in tactics according to the situation. Goldberg goes on rightly to criticize Holland Smith for making the Battle of Saipan sound as though it were exclusively a Marine affair, withholding due encomium for Ralph Smith’s soldiers (p. 152).

Goldberg claims that Saipan was a crucial battle in support of American victory in the Pacific because it ended all prospects of a Japanese success. “Just as the Normandy invasion destroyed Germany’s chances for victory in Europe,” he argues, “the Battle of Saipan ended Japan’s prospects for victory in the Pacific” (p. 214). The Japanese considered Saipan to be crucial to their defense zone. The U.S. invasion of the island prompted the Japanese Navy to seek a decisive battle with the American Fifth Fleet that guarded U.S. amphibious operations on Saipan. The first battle of the Philippine Sea, also known as the “Great Marianas Turkey Shoot” on 19 June 1944, was a terrible defeat for Japan, which lost hundreds of planes, pilots, and three aircraft carriers (p. 101). The battle set the U.S. Navy up for a victory in the Battle of Leyte Gulf in October 1944. Goldberg argues that “it had been the reduction in Japan’s air strength at the First Battle of the Philippine Sea that paved the way for the destruction of Japan’s surface ships at Leyte Gulf” (p. 102).

This great naval victory, however, was tainted by the squabbling of U.S. Navy Vice Admiral Marc A. Mitscher and Admiral Raymond A. Spruance, com-

mander of the Fifth Fleet. The two men differed on attack plans against the Japanese fleet. Mitscher, aggressive and impatient, wanted to give chase and sink the remaining Japanese fleet. Spruance, on the other hand, the more cautious, deliberate, and in overall command of the Saipan operation, decided that pursuing the Japanese fleet would leave ground troops on Saipan dangerously exposed. Spruance decided to let the Japanese steam away. Despite the bickering that occurred afterward, Goldberg praises both commanders: “Spruance’s defensive plan led to a decisive American victory, while Mitscher’s launch schedule decimated Japanese resources” (p. 211).

*D-Day in the Pacific* does a fine job of supporting the above contentions, but it excels in capturing the horror of what the Marines and U.S. Army soldiers on Saipan experienced during the battle. From the amphibious assault on 15 June to the *gyokusai* on 6–7 July, troops on both sides struggled with sleep deprivation, fear, hunger, and exhaustion amongst the filth, death, and heat. Goldberg’s firsthand accounts from veterans allowed him to paint a lurid and lucid picture of the terrifying battle from the infantryman’s perspective. The book is full of grim moments: Marines forced to watch violent deaths of friends and to see bloated and maggot-infested corpses, and Japanese sneaking into aid stations to bayonet and slit the throats of wounded troops. Of all the narratives, the mass civilian suicide at Marpi Point (the incident Saipan is infamous for) was exceptionally tragic. Japanese soldiers convinced Saipan civilians that they would suffer a fate worse than death if captured by American forces. Therefore, hundreds of men, women, and children plummeted from the cliffs to their deaths needlessly. “The scene was grisly even for battle veterans, and many marines and soldiers were haunted by the memories” (p. 202).

*D-Day in the Pacific* is highly commendable for what it accomplishes. Goldberg argues persuasively the effects of Japanese tactics, the root cause of Marine and Army tension during the battle, and the importance of the battle in bringing the war to a close. Though the book focuses on the Corps’ history, it is unsupported by any material from the Marine Corps Archives and Special Collections in Quantico, Virginia, and provides infrequent references from the National Archives in Washington, DC. Goldberg’s interpretations, especially regarding the strategic

importance of Saipan, are not new. Jeter A. Isely and Philip A. Crowl attached similar importance to the battle in *The U.S. Marines and Amphibious War* (1951). George W. Garand and Truman R. Strobridge, authors of *Western Pacific Operations: History of U.S. Marine Corps Operations in World War II* (1971), also argued the significance of Saipan. More

archival sources may have influenced Goldberg's already well-considered conclusions and might have led him to new interpretations. Nevertheless, Goldberg's work will be useful to World War II military and naval historians, both professional and amateur. This book is tough to read, but a good book on a terrible battle should be. ♦1775♦

## BOOK REVIEW

# *A Call to Arms:* Mobilizing America for World War II

Reviewed by Bradford A. Wineman  
Associate professor of military history  
Marine Corps University Command and Staff College

*A Call to Arms: Mobilizing America for World War II.* By Maury Klein. (New York: Bloomsbury Publishing, 2015. Pp. 912. \$40.00 cloth; \$25.00 paperback; \$16.99 e-book.)

**M**aury Klein's *A Call to Arms* escorts the reader through the experience of the American home front during World War II, focusing on three key misconceptions about the mobilization process and its success. The first is forgetting the nation's late entry into the war—the war began almost two years before the attack on Pearl Harbor. While the American people launched themselves into supporting the military effort after 7 December 1941, President Franklin D. Roosevelt (FDR) had been laying the groundwork for the nation's transition to a war footing by gradually reacting to the events of the growing conflict in Europe and preparing at home. By late 1941, FDR had sent a myriad of supplies to England, shut off resources to Japan, stockpiled crucial war materiel domestically, and instituted the first peacetime draft in American history. In sum, the nation already had a running start upon entering the conflict.

The second misconception relates to the first in how the experiences of World War I, mostly negative, affected America's entrance into World War II

*Bradford A. Wineman, PhD, is an associate professor of military history at Marine Corps University's Command and Staff College, Quantico, VA. He is the author of "We Will Fight Them . . .": The Experience of British Civilians during the 'Blitz,'" in Personal Perspectives: World War II, edited Timothy C. Dowling (2005).*

and the country's subsequent mobilization. Business owners shuddered at the prospect of having to forfeit production controls to the government, and citizens bitterly recalled the rampant war profiteering of industry captains whom they labeled "merchants of death" during the interwar period (p. 14). For many Americans,

the memory of the Great War was characterized as much by corruption and coercion as by patriotism and unity.

The last and most damaging misconception is that of the "Greatest Generation." According to Klein, the civilian home front was not as unified, hard working, and selfless as Tom Brokaw would have his readers believe. Klein chronicles cases of citizens circumventing the rationing requirements, shirking their work at industrial jobs, and halting production with labor strikes. According to Klein's persuasive narrative, rampant self-interest and greed from both individuals and institutions perennially marred the war effort.

Klein is a celebrated economic historian and professor emeritus at the University of Rhode Island. His research into the methodology and process of American industrial production is nothing short of extraordinary. He describes the step-by-step construction of bombers, liberty ships, and other machines of war. The technical explanations of

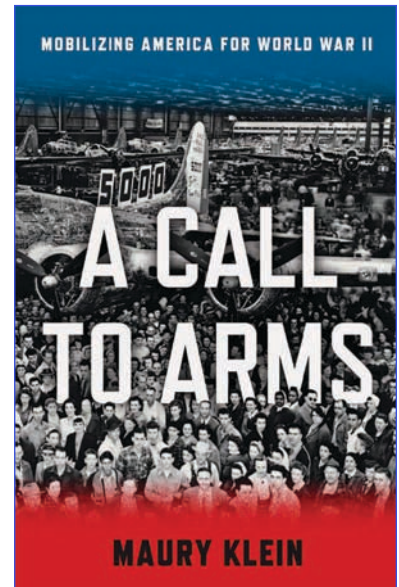

the war assembly-line procedures alone would be stultifying to the reader if not for Klein's numerous and well-placed anecdotes of the American workers and managers that humanize the cold, unfeeling machinations of the war's production activities. These anecdotes also allow the author's economic analysis to illuminate discussions on the social and cultural consequences of the drastic changes social and economic changes taking place, both positive (increased economic opportunities for women and minorities) and negative (missed opportunity to address institutionalized racism), in the United States.

Although Klein examines the roles of institutions, businesses, and broader economic trends, he habitually steers his explanation to the role of leadership, specifically that of FDR, as the true key to American home front success. As mentioned previously, FDR had the foresight to prepare the nation for the war despite substantial isolationist and pacifist opposition. Once America entered the conflict, FDR discovered that some of his greatest enemies were at home: isolationists, reluctant corporate executives, and even stalwart New Dealers in his own

party. Throughout the war, FDR adeptly balanced the delicate variables of manpower, prices, resources, and government power to maintain success on the battlefield and harmony at home. While it took millions of citizens to create and operate the "arsenal of democracy," (pp. 128–29) Klein posits that FDR put all the various pieces together and willed the United States population to victory through his organization, doggedness, and charisma.

The book's only major shortcoming is the ending. After nearly 800 pages of painstakingly researched narrative tracing the United States' journey through the war, Klein offers only a pithy two pages on America after the dropping of the atomic bombs. He asks ambiguous rhetorical questions about "What did it all mean?" but never attempts to give answers. With so much rich explanation about the mobilization process, the book leaves the reader wanting for a concluding analysis, tying together all of the facts and elucidating on the broader long-term impact on U.S. economics, society, government, and culture. Regardless, this volume stands out as the gold standard for scholarship on the World War II American home front. ♦ 1775 ♦

## BOOK REVIEW

# WWII: A Chronicle of Soldiering

Reviewed by Chris Blaker  
Oakland University in Rochester, Michigan

*WWII: A Chronicle of Soldiering*. By James Jones. (Chicago: University of Chicago Press, 1975, 2014 rev. ed. Pp. 216. \$17.00 paper and e-book.)

In the revised edition of *WWII: A Chronicle of Soldiering*, James Jones examines the evolution, and later de-evolution, of the civilian-soldier during the war from 1941 to 1946. The book presents a collection of Jones's essays originally written to complement war art for a 1975 World War II picture book.

Best known for his World War II trilogy—*From Here to Eternity* (1951), *The Thin Red Line* (1962), and *Whistle* (1978)—Jones uses personal experiences as a mud-slogging infantryman in the Pacific and pens vivid accounts of the war. Jones's work jumps from his own memories at Pearl Harbor and Guadalcanal to the contributions of war correspondents and painters, including accounts of how politicians and high-level military officers planned and executed incredible operations against the Axis Powers. The author attempts to create a historical cocktail, a blending of personal and social but also historical and fictional perspectives. *WWII: A Chronicle of Soldiering* is an all-encompassing compilation of wartime experiences. The anthological structure moves the book freely from topic to topic but requires the reader to follow along carefully as essays and commentaries often

*Chris Blaker previously worked at the U.S. Marine Corps History Division, Quantico, Virginia. He is pursuing a master's degree in American history at Oakland University in Rochester, Michigan, and is writing his thesis on Marine Corps organization during the Vietnam War.*

interrupt the more traditional telling of military histories.

Some of Jones's essays discuss the evolution of war art in both theaters of the war—the Pacific and Europe. The war art selections included in this volume complement Jones's writing style. He describes how early art in *Yank* magazine cheered on enlisted soldiers; its humor

addressed their everyday problems in a way that even they could laugh at. Later cartoons, such as those drawn by Bill Mauldin, and more serious publications, such as *Life* and *Time* magazines, continued to promote war art. American Servicemen even contributed to the phenomenon themselves: infantrymen reproduced the popular doodle of "Kilroy" across the battlefields and pilots painted nose art on their planes. The strength of war art, as proven by both its creators and consumers, comes from its honesty and nonpolitical means of describing the war experiences of those directly involved. Whether the work was light or serious in nature, soldiers appreciated the truth.

The evolution and de-evolution of the American soldier, however, remains Jones's focal point. He notes that, while the United States went to great lengths to train and prepare its civilian-soldiers for war, the country did far less to assimilate them into peacetime society upon their return home. The author also presents a downside to America's indomitable wartime industry. He argues that the rapidly

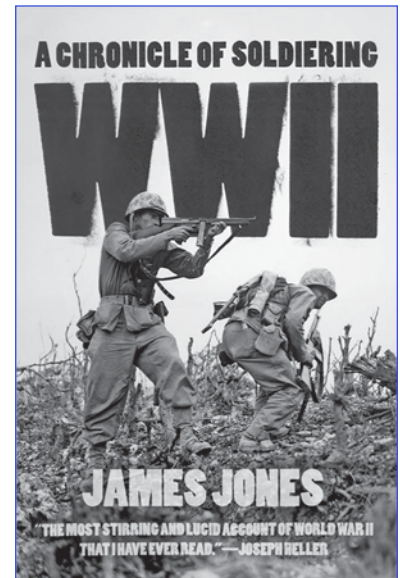

expanding size of military forces and a dependence on machines threatened to overshadow the infantryman, condemning him to become simply a cog in an industrial machine rather than a distinct element of American military might. Jones's writing reflects this transition as well, whether intentional or not. The author concentrates on the soldier, squad, and company on Guadalcanal and in North Africa. But by the time Operation Overlord and Okinawa occur, the corps- and army-size campaigns overshadow the book's thesis: the individual soldier.

Ultimately, Jones's work offers a unique view of the war presented as a collection of military histories, political and social commentaries, psychological hypotheses, and cultural developments. His work views the war from many angles and, by doing so, creates a wide lens through which to assess the conflict. The author's observations on varied topics draws suspicion to his defense of a single thesis, but Jones masterfully presents the war to his readers exactly as it appeared to the very servicemen he seeks to remember. ♦ 1775 ♦





## Submissions

Marine Corps History Division is actively searching for contributors to *Marine Corps History* (MCH). MCH is a scholarly, military history periodical published twice a year (Summer and Winter). Our focus is on all aspects of the Corps' history, culture, and doctrine. Articles should be no less than 4,000 words and footnoted according to *Chicago Manual of Style*. For more information about submitting an article or writing a book review, please email [history.division@usmc.mil](mailto:history.division@usmc.mil) with the subject line of "Marine Corps History Submission."

### ***New History Division Publication!***

#### ***U.S. Marines and Irregular Warfare*** *Training and Education, 2000–2010*

Dr. Nicholas J. Schlosser

*U.S. Marines and Irregular Warfare* covers a period of considerable intellectual activity for the U.S. Marine Corps. The initial fighting during the Iraq and Afghanistan Wars convinced many Marine leaders that it needed to strengthen and enhance how it trained and educated Marines in counterinsurgency (COIN) operations. This book recounts the work of Marines and educators in the field and at home at Marine Corps Base Quantico, Virginia, and at Marine Corps Air Ground Combat Center, Twentynine Palms, California.

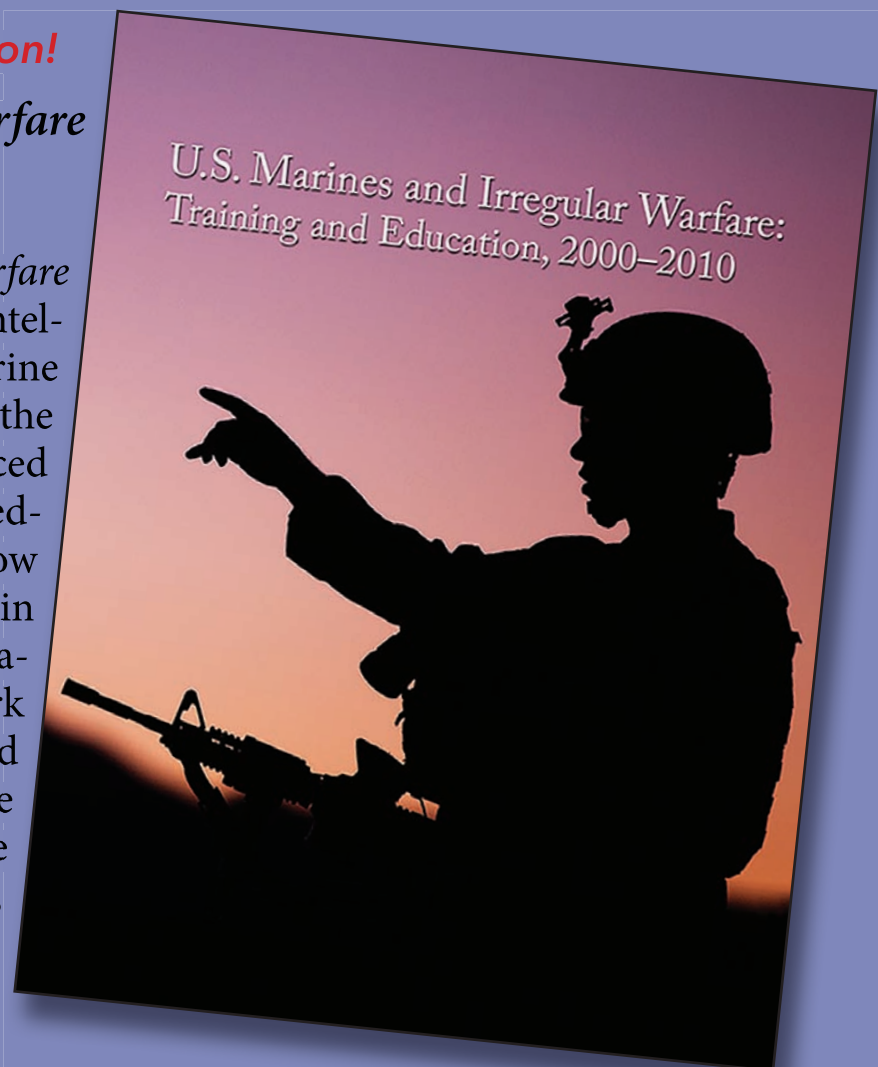

# Story to tell?

*Marine Corps History* is currently accepting article and book review submissions for 2016–17.

For more information about submission guidelines or history books available for review, please contact the senior editor at [angela.anderson@usmcu.edu](mailto:angela.anderson@usmcu.edu).



## U.S. Marines in Afghanistan, 2001–2009

### *Anthology and Annotated Bibliography*

Major David W. Kummer

This anthology and bibliography presents a collection of 37 articles, interviews, and speeches describing many aspects of the U.S. Marine Corps participation in Operation Enduring Freedom from 2001 to 2009. This History Division publication is intended to serve as a general overview and provisional reference to inform both Marines and the general public until monographs dealing with major Marine Corps operations during the campaign can be completed. The accompanying annotated bibliography provides a detailed look at selected sources that currently exist until new scholarship and archival materials become available.

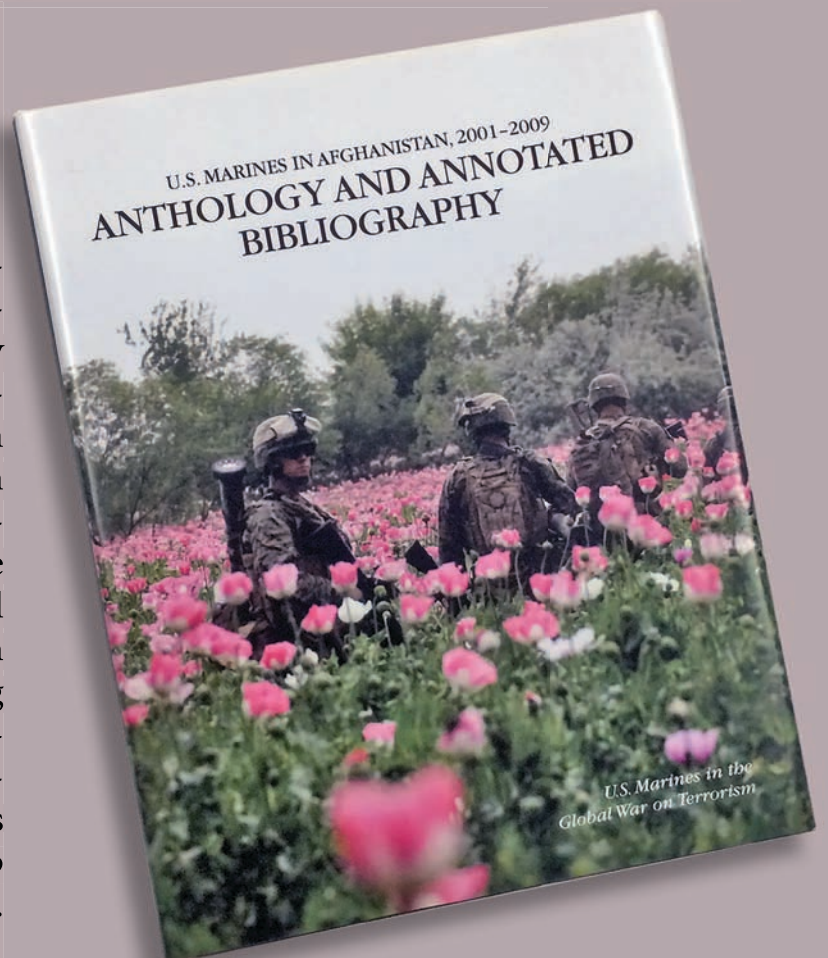

# MARINE CORPS HISTORY DIVISION'S *New Releases*

## ***The Path to War***

*U.S. Marine Corps Operations in Southeast Asia, 1961 to 1965*

Colonel George R. Hoffmann Jr. (Ret)

Book one of this commemorative series documents the activities of the U.S. Marine Corps in Southeast Asia from January 1961 to March 1965, during which time Marines saw increased involvement in the region as they served to protect American interests. While individual Marines saw duty as early as 1954 with the U.S. Military Assistance Advisory Group in Saigon, the first operational unit of 300 Marines from Marine Air Base Squadron 16 was deployed to Udorn, Thailand, in March 1961 to provide aircraft maintenance and flight-line support for Air America.

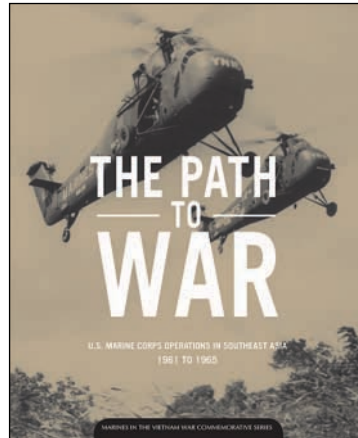

## ***The United States Marine Corps in the World War***

Major Edwin N. McClellan

*The United States Marine Corps in the World War* provides succinct, factual, and historical information on the Marine Corps during the First World War. Published initially in 1920 as the first book from the newly created Historical Section of the Marine Corps, Major Edwin N. McClellan's history of Marines in the first global war has stood the test of time with its statistical and concise details of the growth, activities, and combat exploits of Marines. During the 50th anniversary of the First World War, History Division provides an updated version that accounts for more accurate casualty numbers. In honor of the centennial of the First World War, this expanded version now includes short biographical sketches on key Marine Corps leaders in the war and photographs within the text. This reprint of McClellan's seminal work is the first in a series commemorating Marines in the war.

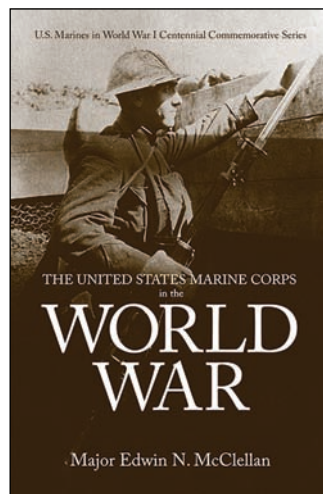

## ***The First Fight***

*U.S. Marines in Operation Starlite, August 1965*

Colonel Rod Andrew Jr., U.S. Marine Corps Reserve

Operation Starlite, as the Marines called it, took place on the Van Tuong Peninsula, about 10 miles south of the Marine base at Chu Lai. In the short term, the tactical victory won by the Marines validated such operational concepts as vertical envelopment, amphibious assault, and combined arms that had not been put into practice on a large scale since the Korean War. It proved that Marine ground troops and their junior officers and noncommissioned officers, as well as Marine aviators, were just as tough and reliable as their forebears who had fought in World War II and Korea. In the long term, Starlite foreshadowed the American military's commitment to conventional warfare in Vietnam and showed how difficult it would be to defeat Communist forces in South Vietnam.

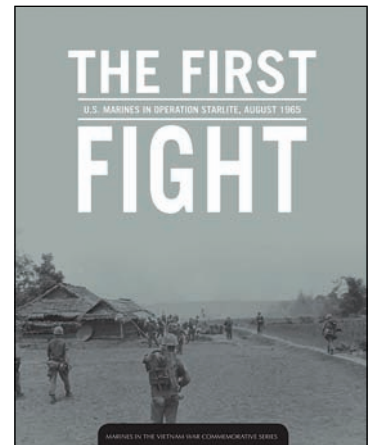

## ***The U.S. Marine Corps in the First World War*** *Anthology, Selected Bibliography, and Annotated Order of Battle*

Annette D. Amerman

The aim of this collection of articles is to give readers the broad historical strokes to U.S. Marine Corps participation in World War I, as well as to show that the Corps' contribution to the war effort was not limited to the 4th Marine Brigade. World War I created the modern-day Marine Corps; an adaptive force-in-readiness even when seemingly relegated to ship and barracks duty.

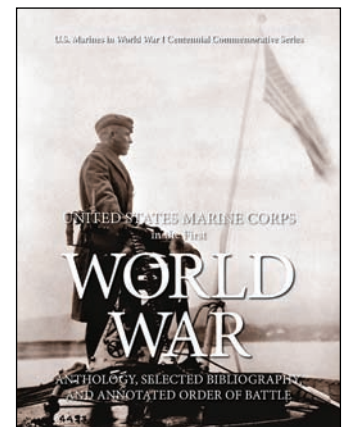

## *Marine Corps History*

Issues of *Marine Corps History* can be found on the History Division website at <https://www.history.usmc.mil> under Publications.

